

155™ Single and 255™ Dual Cartridge Seals

Patented



- Global acceptance and satisfaction across a variety of industrial applications
- Exclusive face design for superior emissions control capability
- Stable, secure sealing under fluctuating conditions
- Patented features assure precision alignment from start-up
- Versatile and cost-effective



*Delivering the best value
in cartridge sealing today*

155™ Cartridge Single Seal

Construction Details

- 1 All O-rings are either static or move on non-metallic, non-fretting surfaces.
- 2 Seal face support shoulder is precisely square.
- 3 Integral drive pads cannot fall out.
- 4 Hydraulically balanced faces for low frictional heat.
- 5 Flush port can be rotated 360° for ease of piping as required.
- 6 Stationary springs, isolated from fluid to prevent clogging.
- 7 Patented Adjustable Gland™ fits common bolt arrangements without modification.
- 8 Self-Centering Lock Ring™ for superior concentricity.
- 9 Centering strap for simple installation.

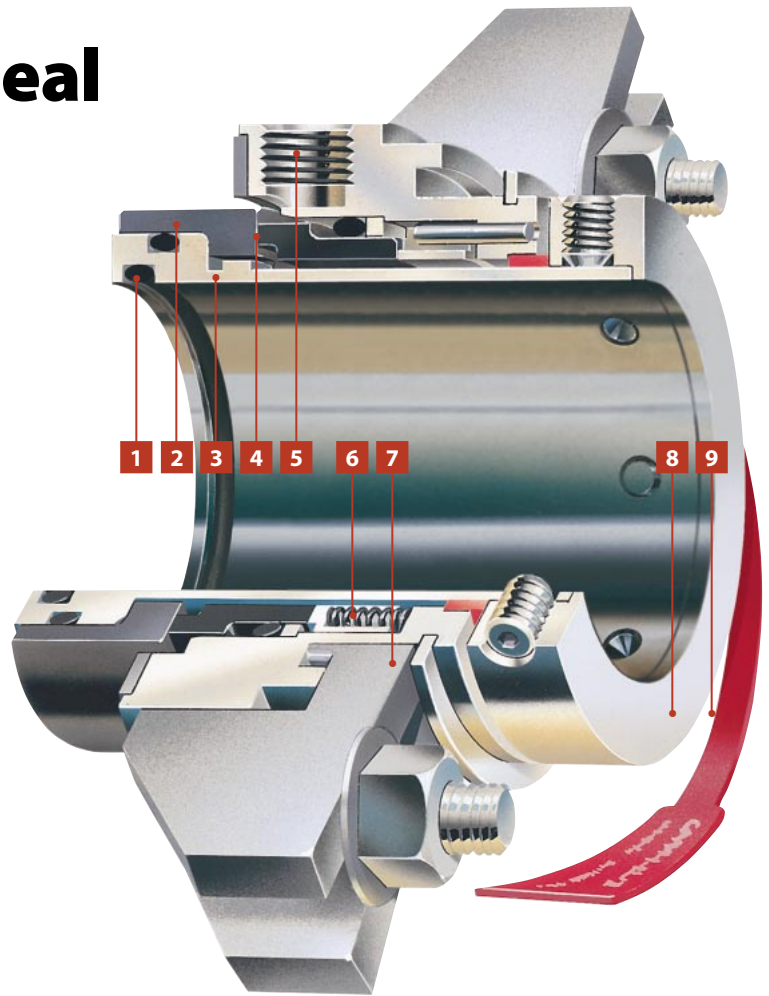

Self-Centering Lock Ring™ ensures reliability

The patented Self-Centering Lock Ring makes installation precise for correct face mating and sustainable sealing. Cloverleaf 3-point contact ensures concentricity to the shaft. Faces start out square and stay square to prevent the intrusion of contaminants or abrasives. Also, constant face squareness reduces opportunities for fluid leakage and uneven wear.

Superior reliability during system variations

Pressure surges at start-up and shut-down can create seal reliability problems. The 155 seal can handle 50% to 100% greater transient pressure than conventional seals and provides a "margin of safety" during normal surges.



CHESTERTON 155 Seal ■
Conventional Seal ■

Dynamic stress relief keeps faces closed

Variances in temperature or pressure, fluid phase changes, or water hammer can create dynamically changing stresses on the seal faces. Common face geometries distort at the mating surface under such conditions and create drastic wear. Chesterton face geometry compensates for stresses in the body of the seal ring, away from the critical face mating surfaces.

Face material interchangeability

With the 155, the interchanging is a fast and easy process, with seal function and reliability assured. Standard face materials are silicon carbide or carbon. The carbon can be swapped for silicon carbide, tungsten carbide or Duplex Carbide™, which provides the utility of two hard faces but with lower frictional heat. All faces are interchangeable with the 225 and 255 dual seals.



255™ Cartridge Dual Seal

Construction Details

- 1 Every O-ring is either static or moves on a non-fretting, non-metallic surface.
- 2 Precision seal ring support shoulder maintains rotary alignment.
- 3 Inboard rotary and stationary faces. Dynamic stress-relieving seal rings, mated over a narrow cross-section for low heat generation.

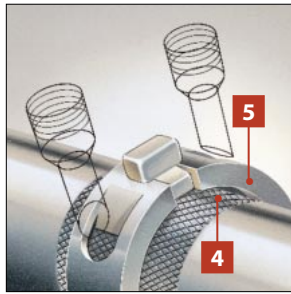

- 4 Profiled sleeve provides positive pumping of barrier fluid.
- 5 Patented shuttle slides within gland to decouple faces from gland misalignment, channel barrier fluid, and provide anti-rotation for stationary seal rings.
- 6 Barrier fluid ports provide high capacity cooling.
- 7 Universal gland fits majority of pumps. ANSI oversize and API glands available.
- 8 Outboard stationary and rotary faces, identical to inboard set for simple assembly, low replacement inventory.
- 9 Inboard and outboard integral drive pads cannot loosen or fall out.
- 10 Patented Self-Centering Lock Ring™ for superior concentricity.
- 11 Revolutionary Unified Seal Alignment™ requires only one set of springs to provide constant loading of all four faces. Springs are isolated from process and barrier fluids.

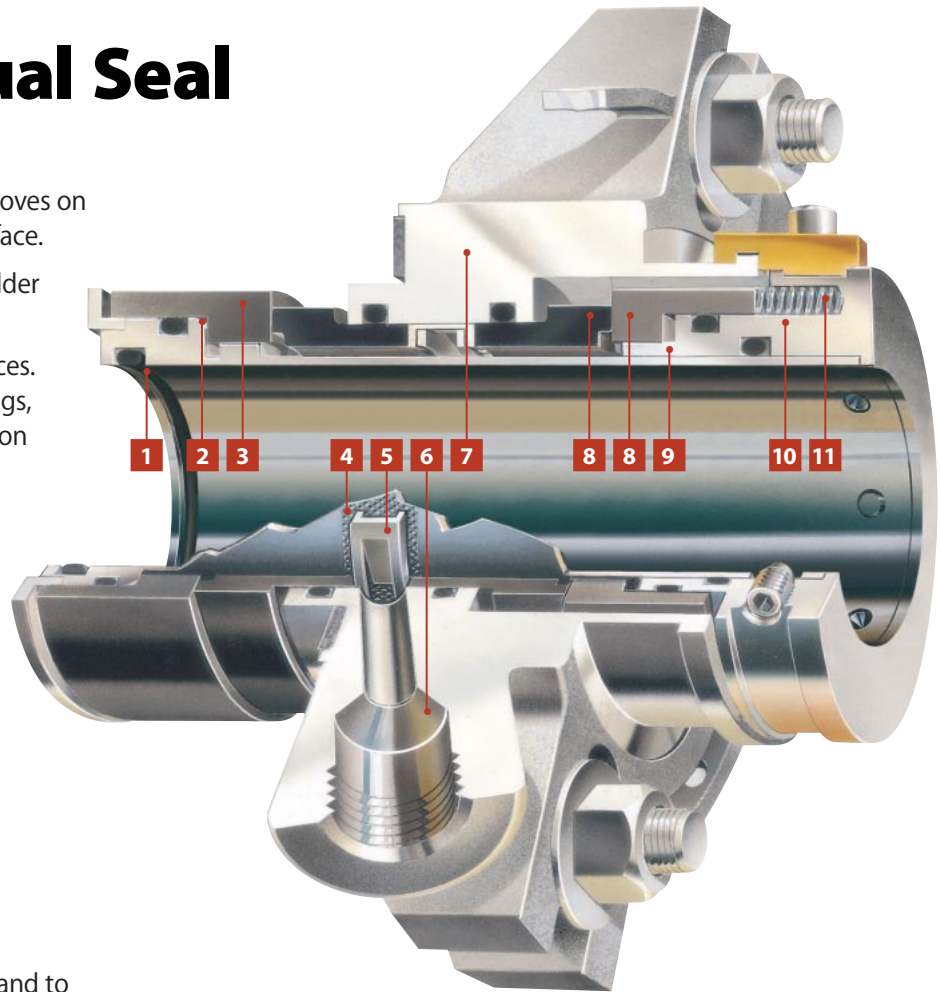

Built for the future of emissions control

The Chesterton 255 seal is designed to meet environmental regulations for emissions control.

Advanced technology for applications flexibility

The exclusive design of the 255 enables it to operate in double-mode (barrier fluid pressure higher than stuffing box pressure) or tandem-mode (barrier fluid pressure lower than stuffing box pressure).

Staying cool in operation and under pressure

The 255 handles 50% to 100% more pressure than typical seals, providing users with a "margin of safety" at start-up and shut-down when transient surges often occur. The 255 features an internal positive barrier fluid pumping system with wide flow channels for efficient removal of heat. To test the 255's cool running, the 255 and a widely used competitive double seal were run under identical conditions with repeated shutoffs. **Test conditions:** 1.875" (48 mm) shaft, water barrier fluid room temperature, 1750 RPM, closed convection system. **Results:** 255 ran cool and steady while the conventional seal overheated and flashed.

155 STANDARD – Dimensional Data/Inch

SHAFT SIZE	GLAND OD	STUFFING BOX BORE		SB DEPTH	OB LENGTH	BOLT CIRCLE BY BOLT SIZE			
		B MAX	C MIN			C MAX	E MIN	F	G/ MIN
						3/8"	1/2"	5/8"	3/4"
1.000	4.65	1.75	2.00	0.63	1.89	2.88	3.01	3.13	-
1.125	4.69	1.88	2.03	0.63	1.89	2.92	3.05	3.17	-
1.125***	4.69	1.88	2.03	0.63	1.89	2.92	3.05	3.17	-
1.250	4.90	2.00	2.26	0.63	1.89	3.13	3.26	3.38	-
1.375	5.04	2.13	2.42	0.63	1.89	3.27	3.40	3.52	-
1.375***	5.04	2.00	2.42	0.63	1.89	3.27	3.40	3.52	-
1.500	5.23	2.25	2.62	0.63	1.89	3.46	3.59	3.71	-
1.625	5.29	2.38	2.68	0.63	1.89	3.52	3.65	3.77	-
1.750	5.41	2.50	2.80	0.63	1.89	3.64	3.77	3.89	-
1.875	5.53	2.63	2.93	0.63	1.89	3.76	3.89	4.01	-
2.000	5.74	2.75	3.18	0.63	1.89	3.97	4.10	4.22	-
2.125	6.04	2.88	3.43	0.63	1.89	4.27	4.40	4.53	-
2.250	6.14	3.00	3.55	0.63	1.89	4.38	4.51	4.63	-
2.375	6.29	3.13	3.59	0.63	1.89	4.52	4.65	4.77	-
2.500	6.41	3.25	3.80	0.63	1.89	4.65	4.78	4.90	-
2.625	7.63	3.63	4.00	0.88	2.50	-	5.35	5.48	5.60
2.750	7.76	3.75	4.13	0.88	2.50	-	5.48	5.60	5.73
2.875	7.88	3.88	4.25	0.88	2.50	-	5.60	5.73	5.85
3.000	8.01	4.00	4.44	0.88	2.50	-	5.73	5.85	5.98
3.125	8.13	4.13	4.55	0.88	2.50	-	5.85	5.98	6.10
3.250	8.26	4.25	4.69	0.88	2.50	-	5.98	6.10	6.23
3.375	8.38	4.38	4.80	0.88	2.50	-	6.10	6.23	6.35
3.500	8.51	4.50	4.94	0.88	2.50	-	6.23	6.35	6.48
3.625	8.63	4.63	5.05	0.88	2.50	-	6.35	6.48	6.60
3.750	8.76	4.75	5.14	0.88	2.50	-	6.48	6.60	6.73
3.875	8.88	4.88	5.26	0.88	2.50	-	6.60	6.73	6.85
4.000	9.01	5.00	5.44	0.88	2.50	-	6.73	6.85	6.98
4.125	9.13	5.13	5.55	0.88	2.50	-	6.85	6.98	7.10
4.250	9.18	5.25	5.69	0.88	2.50	-	6.89	7.02	7.14
4.375	9.30	5.38	5.81	0.88	2.50	-	7.02	7.14	7.27
4.500	9.43	5.50	5.94	0.88	2.50	-	7.14	7.27	7.39
4.625	9.56	5.63	6.06	0.88	2.50	-	7.27	7.39	7.52
4.750	9.76	5.75	6.22	0.88	2.50	-	7.47	7.60	7.72

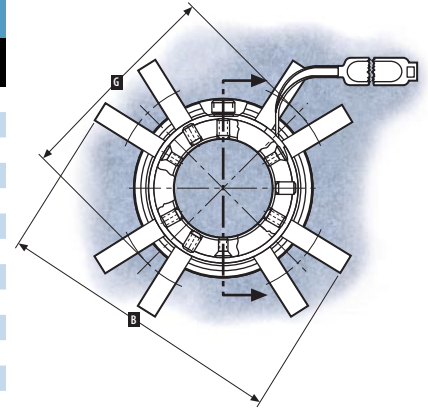

155 – Standard Version

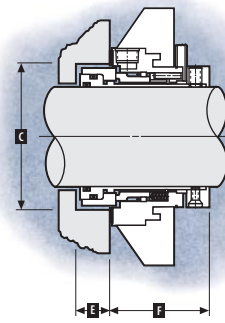

155 STANDARD – Dimensional Data/Metric

SHAFT SIZE	GLAND OD	STUFFING BOX BORE		SB DEPTH	OB LENGTH	BOLT CIRCLE BY BOLT SIZE			
		B MAX	C MIN			C MAX	E MIN	F	G/ MIN
						8 mm	10 mm	12 mm	16 mm
25	118	44	51	16	48	70	72	74	-
28	118	47	52	16	48	70	72	74	-
30	124	49	57	16	48	76	78	80	-
32	124	51	58	16	48	77	79	81	-
33	124	52	59	16	48	76	78	80	-
35	128	54	62	16	48	80	82	84	-
38	133	57	67	16	48	85	87	89	-
40	134	59	68	16	48	86	88	90	-
43	134	62	69	16	48	86	88	90	-
45	140	64	73	16	48	92	94	96	-
48	139	67	74	16	48	91	93	95	-
50	145	69	78	16	48	97	99	101	-
55	150	74	83	16	48	102	104	106	-
60	160	79	91	16	48	112	114	116	-
65	194	92	102	22	64	-	132	134	138
70	197	95	105	22	64	-	135	137	141
75	203	100	113	22	64	-	141	143	147
80	207	105	116	22	64	-	144	146	150
85	213	110	122	22	64	-	151	153	157
90	216	115	125	22	64	-	154	156	160
95	222	120	131	22	64	-	160	162	166
100	229	127	138	22	64	-	167	169	173
110	236	136	148	22	64	-	174	176	180
120	248	145	158	22	64	-	186	188	192

STANDARD MATERIALS**

Rotary Faces:

- Silicon Carbide
- Tungsten Carbide

Stationary Faces:

- Duplex Carbide™
- Carbon
- Silicon Carbide
- Tungsten Carbide

All Metal Parts:

- 316SS

Springs:

- Hastelloy C*

O-Rings:

- Fluorocarbon or AFLAS† installed;
- EPR included

OPERATING LIMITS

Speed Limits:

- To 4000 fpm (20 mps)

Temperature Limits:

- To 300°F (150°C)
Ethylene Propylene
- To 400°F (205°C)
Fluorocarbon, AFLAS
- To 500°F (260°C)
Perfluoroelastomer

Pressure Limits:

- To 600°F (40 bar)

* Haynes International, Inc Registered Trademark.

** Other materials available upon request. *** 155T Sizes.

† Asahi Glass Company Ltd. Registered Trademark.

155 CAST – Dimensional Data/Inch

SHAFT SIZE	GLAND OD		STUFFING BOX BORE		SB DEPTH		OB LENGTH		BOLT CIRCLE BY BOLT SIZE		
	B MAX	C MIN	C MAX	E MIN	F	3/8"	G/MIN 1/2"	5/8"			
1.000	4.13	1.75	2.00	0.47	1.98	2.88	3.01	–			
1.125	4.13	1.88	2.03	0.47	1.98	3.01	3.13	–			
1.250	4.13	2.00	2.26	0.47	1.98	3.13	3.26	–			
1.500	5.01	2.25	2.62	0.47	1.98	3.38	3.51	–			
1.625	5.01	2.38	2.66	0.47	1.98	3.51	3.64	–			
1.750	5.51	2.50	2.80	0.47	1.98	3.63	3.76	–			
1.875	5.51	2.63	2.93	0.47	1.98	3.76	3.88	–			
2.000	5.51	2.75	3.18	0.47	1.98	4.01	4.13	–			
2.125	6.01	2.88	3.28	0.47	1.98	4.26	4.38	4.51			
2.250	6.01	3.00	3.55	0.47	1.98	4.38	4.51	4.63			
2.375	6.01	3.13	3.59	0.47	1.98	4.42	4.55	4.67			
2.500	6.52	3.25	3.80	0.47	1.98	4.64	4.76	4.89			

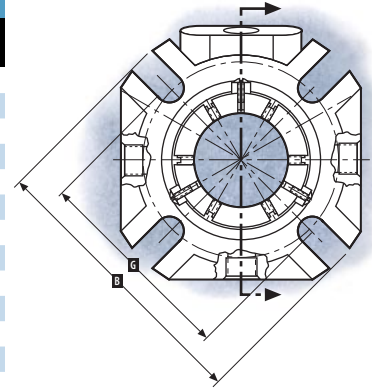

155 – Cast Version

155 CAST – Dimensional Data/Metric

SHAFT SIZE	GLAND OD		STUFFING BOX BORE		SB DEPTH		OB LENGTH		BOLT CIRCLE BY BOLT SIZE		
	B MAX	C MIN	C MAX	E MIN	F	8 mm	G/MIN 10 mm	12 mm			
25	105	44	51	12	50	72	74	76			
28	105	47	52	12	50	75	77	79			
30	105	49	57	12	50	76	78	80			
32	105	51	58	12	50	78	80	82			
33	114	52	59	12	50	79	81	83			
38	127	57	67	12	50	84	86	88			
40	127	59	68	12	50	86	88	90			
43	127	62	69	12	50	89	91	93			
45	140	64	73	12	50	90	92	94			
48	140	67	74	12	50	93	95	97			
50	140	69	78	12	50	95	97	99			
55	153	74	83	12	50	100	102	104			
60	153	79	91	12	50	111	113	115			

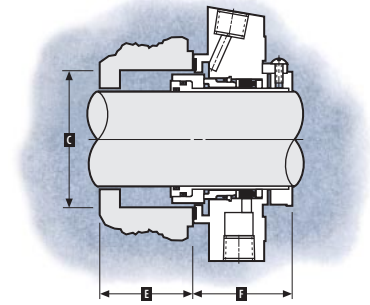

155 OVERSIZE – Dimensional Data/Inch

SHAFT SIZE	GLAND OD		STUFFING BOX BORE		SB DEPTH		OB LENGTH		BOLT CIRCLE BY BOLT SIZE			
	B MAX	C MIN	C MAX	E MIN	F	3/8"	1/2"	G/MIN 5/8"	3/4"	7/8"		
1.125	5.29	2.50	2.75	0.63	1.89	3.59	3.72	3.84	–	–		
1.375	5.57	2.68	3.00	0.63	1.89	3.86	3.99	4.11	–	–		
1.750	6.64	3.37	3.75	0.63	1.89	4.93	5.06	5.18	–	–		
1.875	6.58	3.42	3.81	0.63	1.89	4.88	5.01	5.13	–	–		
2.125	7.31	3.75	4.25	0.63	1.89	5.60	5.73	5.85	–	–		
2.500	8.14	4.37	4.75	0.63	1.89	6.43	6.56	6.68	–	–		
2.625	8.04	4.38	4.78	0.88	2.50	–	5.83	5.96	6.08	6.21		
2.750	8.04	4.28	4.78	0.88	2.50	–	5.83	5.96	6.08	6.21		
3.000	8.65	4.75	5.39	0.88	2.50	–	6.44	6.57	6.69	6.82		
3.375	8.54	4.78	5.27	0.88	2.50	–	6.33	6.46	6.58	6.71		
3.750	9.63	5.78	6.40	0.88	2.50	–	7.41	7.54	7.66	7.79		
4.125	9.54	5.78	6.27	0.88	2.50	–	7.33	7.46	7.58	7.71		
4.750	11.25	7.03	7.65	0.88	2.50	–	9.04	9.17	9.29	9.42		

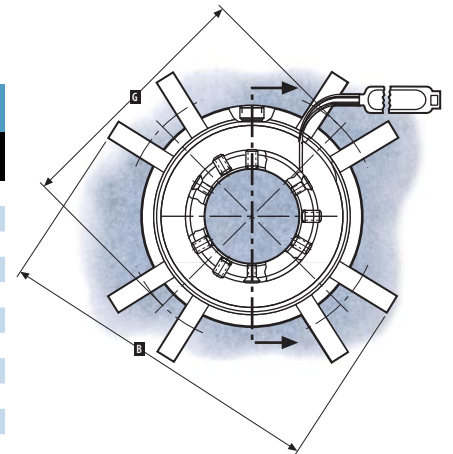

155 – Oversize Version

CONFIGURATIONS TO FIT YOUR APPLICATION NEEDS



CPI Gland:
Quench and drain ports, plus floating throttle bushing, in a slotted, universal gland.



ANSI Oversized Gland:
Patented Adjustable Gland™ available for large bore seal chambers.



155 API:
155 with factory installed glands having piloting, quench, drain and floating carbon throttle bushing to meet API 610.

155B Stationary Bellows:
Configured with Chesterton welded metal bellows. Patented Z-shape face.

155T:
All of 155 features in a compact configuration suited for Duriron Mark II Group I, Goulds 319ST and similar pumps.

155V:
Specially designed to fit Viking Pumps.

155P:
Specially designed for flushless sealing of paper stock up to 3%.

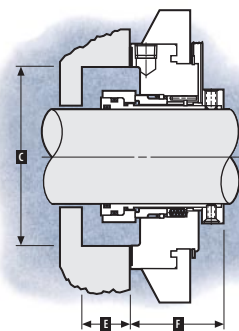

255 STANDARD – Dimensional Data/Inch

SHAFT SIZE	GLAND OD	STUFFING BOX BORE		SB DEPTH	OB LENGTH	BOLT CIRCLE BY BOLT SIZE		
		B MAX	C MIN			C MAX	E MIN	F
1.000	4.12	1.75	1.81	1.36	2.16	2.81	2.94	–
1.125	4.12	1.88	1.94	1.36	2.16	2.95	3.08	–
1.250	4.12	2.00	2.06	1.36	2.16	3.08	3.21	–
1.375	4.37	2.13	2.31	1.36	2.16	3.21	3.34	–
1.500	4.50	2.25	2.44	1.36	2.16	3.33	3.46	–
1.625	5.00	2.38	2.56	1.36	2.16	3.45	3.58	–
1.750	5.50	2.50	2.81	1.36	2.16	3.66	3.79	–
1.875	5.50	2.63	2.94	1.36	2.16	3.78	3.91	–
2.000	5.50	2.75	3.19	1.36	2.16	4.03	4.16	–
2.125	6.01	2.88	3.44	1.36	2.16	4.29	4.42	4.54
2.250	6.01	3.00	3.56	1.36	2.16	4.41	4.54	4.66
2.375	6.01	3.13	3.59	1.36	2.16	4.44	4.57	4.69
2.500	6.51	3.25	3.81	1.36	2.16	4.66	4.79	4.91

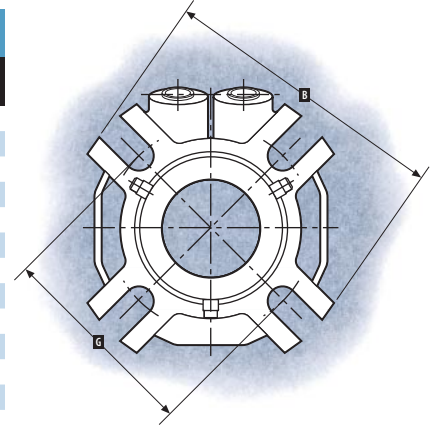

255 – Standard Version

255 STANDARD – Dimensional Data/Metric

SHAFT SIZE	GLAND OD	STUFFING BOX BORE		SB DEPTH	OB LENGTH	BOLT CIRCLE BY BOLT SIZE		
		B MAX	C MIN			C MAX	E MIN	F
25	105	44	46	35	55	70	72	74
28	105	47	49	35	55	73	75	77
30	105	49	51	35	55	76	78	80
32	105	51	52	35	55	77	79	81
33	114	54	58	35	55	78	80	82
35	111	54	59	35	55	80	82	84
38	114	57	62	35	55	83	85	87
40	127	59	61	35	55	86	88	90
43	127	64	69	35	55	89	91	93
45	140	64	66	35	55	93	95	97
48	140	69	74	35	55	94	96	98
50	140	69	71	35	55	98	100	102
55	153	74	76	35	55	–	103	105
60	153	79	85	35	55	–	113	115

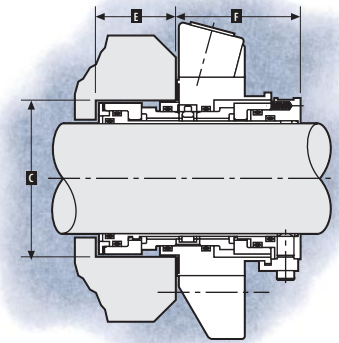

255 ADAPTER VERSION – Dimensional Data/Inch

SHAFT SIZE	GLAND OD	STUFFING BOX BORE		SB DEPTH	OB LENGTH	BOLT CIRCLE BY BOLT SIZE		
		B MAX	C MIN			C MAX	E MIN	F
1.000	4.12	1.75	1.81	1.18	2.35	2.81	2.94	–
1.125	4.12	1.88	1.94	1.18	2.35	2.95	3.08	–
1.250	4.12	2.00	2.06	1.18	2.35	3.08	3.21	–
1.375	4.37	2.13	2.31	1.18	2.35	3.21	3.34	–
1.500	4.50	2.25	2.44	1.18	2.35	3.33	3.46	–
1.625	5.00	2.38	2.56	1.18	2.35	3.45	3.58	–
1.750	5.50	2.50	2.81	1.18	2.35	3.66	3.79	–
1.875	5.50	2.63	2.94	1.18	2.35	3.78	3.91	–
2.000	5.50	2.75	3.19	1.18	2.35	4.03	4.16	–
2.125	6.01	2.88	3.44	1.18	2.35	4.29	4.42	4.55
2.250	6.01	3.00	3.56	1.18	2.35	4.41	4.54	4.67
2.375	6.01	3.13	3.59	1.18	2.35	4.44	4.57	4.70
2.500	6.51	3.25	3.81	1.18	2.35	4.66	4.79	4.92

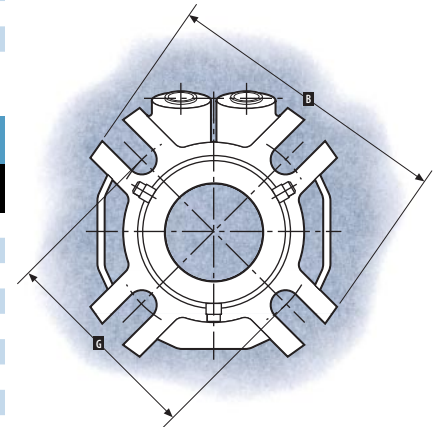

255 – Adapter Version

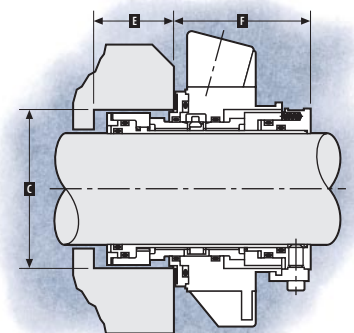

255 LARGE – Dimensional Data/Inch

SHAFT SIZE	GLAND OD		STUFFING BOX BORE		SB DEPTH	OB LENGTH	BOLT CIRCLE BY BOLT SIZE		
	B MAX	C MIN	C MAX	E MIN			F	3/8"	G/MIN 1/2"
2.625	6.45	3.63	3.69	1.64	2.52	5.02	5.15	-	
2.750	7.71	3.75	4.19	1.64	2.52	5.42	5.55	-	
2.875	7.83	3.88	4.32	1.64	2.52	5.50	5.63	-	
3.000	7.94	4.00	4.44	1.64	2.52	5.65	5.78	-	
3.125	7.99	4.13	4.57	1.64	2.52	5.80	5.93	-	
3.250	8.19	4.25	4.69	1.64	2.52	5.93	6.06	-	
3.375	8.31	4.38	4.82	1.64	2.52	6.00	6.13	6.26	
3.500	8.44	4.50	4.94	1.64	2.52	6.16	6.29	6.42	
3.625	8.49	4.63	5.07	1.64	2.52	6.29	6.42	6.55	
3.750	8.72	4.75	5.19	1.64	2.52	6.36	6.49	6.62	
3.875	8.84	4.88	5.32	1.64	2.52	6.50	6.63	6.76	
4.000	8.96	5.00	5.44	1.64	2.52	6.64	6.77	6.90	
4.125	8.99	5.13	5.57	1.64	2.52	6.76	6.89	7.02	
4.250	8.99	5.25	5.69	1.64	2.52	6.89	7.02	7.15	
4.375	9.34	5.38	5.82	1.64	2.52	7.01	7.14	7.27	
4.500	9.49	5.50	5.94	1.64	2.52	7.16	7.29	7.42	
4.625	9.49	5.63	6.07	1.64	2.52	7.26	7.39	7.52	
4.750	10.49	5.75	6.19	1.64	2.52	7.38	7.51	7.64	

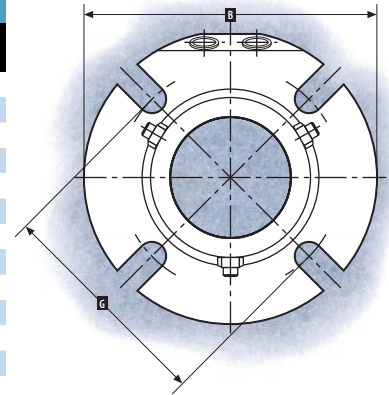

255 – Large Version

255 LARGE – Dimensional Data/Metric

SHAFT SIZE	GLAND OD		STUFFING BOX BORE		SB DEPTH	OB LENGTH	BOLT CIRCLE BY BOLT SIZE		
	B MAX	C MIN	C MAX	E MIN			F	12 mm	G/MIN 16 mm
65	164	92	93	42	64	127	131	-	
70	196	95	105	42	64	137	141	-	
75	202	102	112	42	64	143	147	-	
80	203	105	115	42	64	147	151	-	
85	211	111	121	42	64	152	156	160	
90	214	114	124	42	64	156	160	164	
95	221	121	131	42	64	161	165	169	
100	228	127	137	42	64	168	172	176	
110	237	137	147	42	64	177	181	185	
120	266	146	156	42	64	187	191	195	

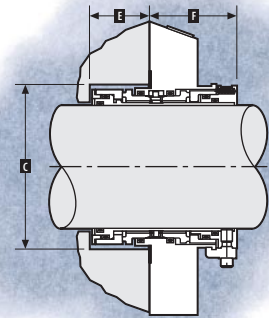

255 OVERSIZE – Dimensional Data/Inch

SHAFT SIZE	GLAND OD		STUFFING BOX BORE		SB DEPTH	OB LENGTH	BOLT CIRCLE BY BOLT SIZE		
	B MAX	C MIN	C MAX	E MIN			F	3/8"	G/MIN 1/2"
1.125	4.49	2.63	2.94	1.48	1.98	3.77	-	-	
1.375	5.40	2.82	2.99	1.48	1.98	4.02	-	-	
1.750	6.64	3.51	3.74	1.30	2.16	5.21	5.34	5.46	
1.875	5.99	3.57	3.80	1.30	2.16	-	4.94	-	
2.125	6.99	3.89	4.24	1.30	2.16	-	-	5.89	
2.500	7.77	4.51	4.74	1.30	2.16	-	-	6.70	

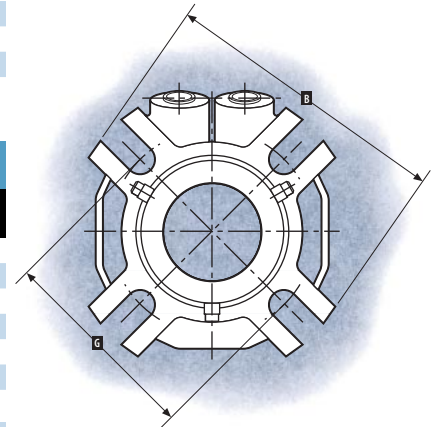

255 – Oversize Version



STANDARD MATERIALS**

Rotary Faces:

- Silicon Carbide
- Tungsten Carbide

Stationary Faces:

- Duplex Carbide™
- Carbon
- Silicon Carbide
- Tungsten Carbide

All Metal Parts:

- 316SS

Springs:

- Hastelloy C*

O-Rings:

- Fluorocarbon or AFLAS† installed; EPR included

OPERATING LIMITS

Speed Limits:

- To 4000 fpm (20 mps)

Temperature Limits:

- To 300°F (150°C) Ethylene Propylene
- To 400°F (205°C) Fluorocarbon, AFLAS
- To 500°F (260°C) Perfluoroelastomer

Pressure Limits:

- To 600°F (40 bar) inboard
- To 250°F (17 bar) outboard

* Haynes International, Inc Registered Trademark.
 ** Other materials available upon request.
 *** 155T Sizes.
 † Asahi Glass Company Ltd. Registered Trademark.

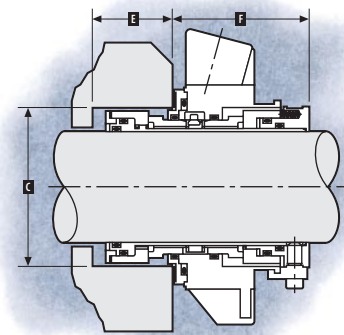

CHESTERTON®

155™ Single and 255™ Dual Cartridge Seals

155 Highly effective emissions control

The advanced design of the 155 and the ability to keep faces square and flat ensures superior emissions control capability.

The 155 has been proven in independent tests to meet or exceed the most stringent USA emissions standards. Of course, for total emissions control or hazardous fluids, use Chesterton new generation dual seals.



255 The low-inventory answer to dual-sealing needs

The 255 meets the needs of applications requiring double and or tandem-mode barrier fluid arrangements, is versatile in terms of choice of materials. The faces are easily changed by the user for hard-face combinations and all wearing parts are user-replaceable.

Fluid flow control

Chesterton Dualflow™ is the advanced regulator for dual seal barrier fluid arrangements. Exclusive, no-maintenance, non-clog design and two-way flow rate detection increase reliability. Ideal for reducing unnecessary water consumption in flow through barrier systems.



Contact your local CHESTERTON Pump and Sealing Specialist for precise system recommendations

Chesterton is the only company in the world with integrated engineering of both pumps and seals. Our engineers have been working for over 15 years to create a synergistic system, between pumps and seals.



Let us help you identify opportunities for cost-savings and greater efficiency at your plant. Distributors can be found at our distributor locator on our website (www.chesterton.com).

The following are trademarks of A.W. Chesterton Company: 155, 255, Self-Centering Lock Ring, Adjustable Gland, Duplex Carbide, Unified Seal Alignment, and Dualflow.



MECHANICAL SEAL DIVISION

Middlesex Industrial Park, 225 Fallon Road
Stoneham, Massachusetts 02180-9101 USA
Telephone: 978-469-6446 Fax: 978-469-6594
www.chesterton.com

DISTRIBUTED BY:

© A. W. CHESTERTON CO., 2000. All rights reserved.
® Registered trademark owned and licensed by
A. W. CHESTERTON CO. in USA and other countries.

FORM NO. 073018

PRINTED IN USA 6/00