

442M™ Split Mixer Seal Installation Instructions

EQUIPMENT PREPARATION

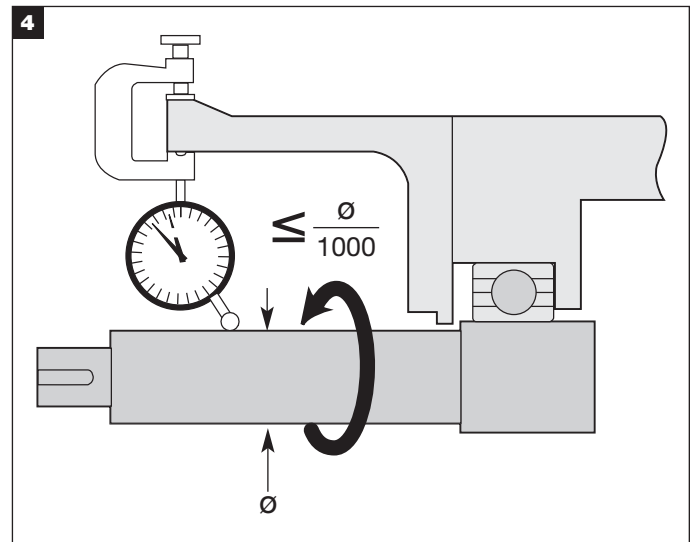
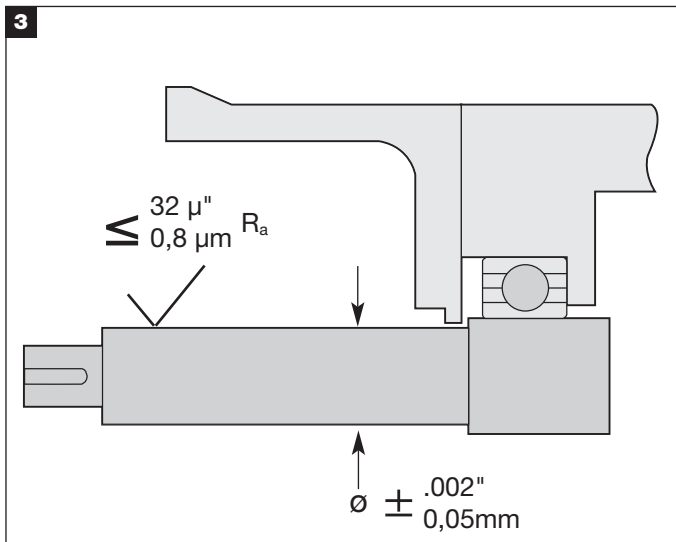
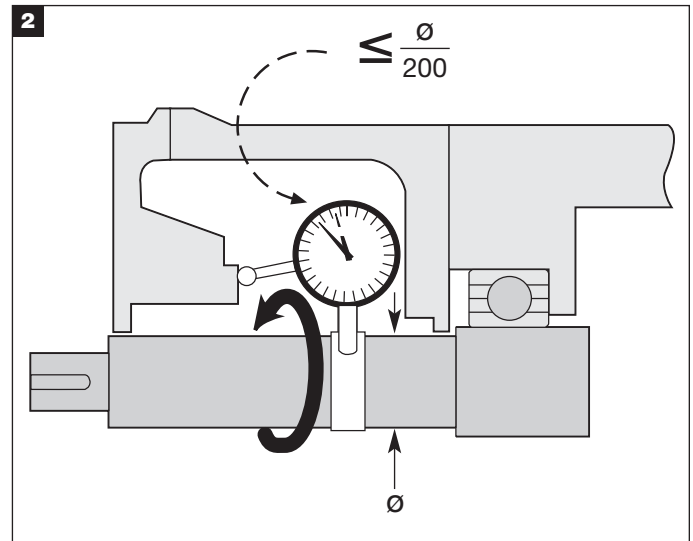
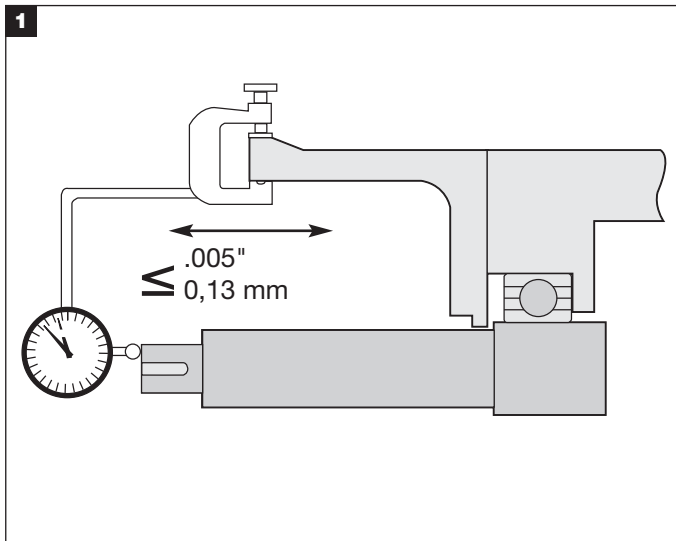

CAUTIONS

These instructions are general in nature. It is assumed that the installer is familiar with seals and certainly with the requirements of their plant for the successful use of mechanical seals. If in doubt, get assistance from someone in the plant who is familiar with seals or delay the installation until a seal representative is available. All necessary auxiliary

arrangements for successful operation (heating, cooling, flushing) as well as safety devices must be employed. These decisions are to be made by the user. The chemical listing is intended as a **general** reference for this seal **only**. The decision to use this seal or any other Chesterton seal in a particular service is the customer's responsibility.

SEAL PREPARATION

Please read these instructions and make sure you understand them before installing the seal.

Installation is easy provided the parts are handled and installed carefully. Make sure your hands are clean. Any dirt particles on the seal faces or splits during handling may cause seal failure. Prepare a clean work surface on which to place parts during assembly/disassembly.

Prepare the Seal for Installation (1-6)

1. Disengage the socket head cap screws from one half of the gland. With the gland in a horizontal position, springs up, separate the halves and place them on the clean work surface.
2. You now have access to the rotary holder. Disengage the two socket head cap screws from one half of the rotary holder and place the holder halves on the clean work surface.
3. Remove the rotary and stationary seal faces from their packages and place on the clean work surface.
4. Make sure that the gland gaskets, holder gaskets, stuffing box gasket (no grease), and shaft o-ring are properly greased and seated in their grooves. Note the gold mark on one end of each half of the cut shaft o-ring. Assure that the o-ring is placed in the rotary holder such that the two gold marks mate at one joint. **Do not glue the gland or holder gaskets in place.**
5. Snap open the ball and socket joint of the O-rings by pulling at the seam. (NOTE: The rotary O-ring is slightly longer and is marked with a purple dot.) **Do not apply grease or glue to the balls and sockets of the O-rings.**
6. Install seal per instructions (pages 3 & 4).

NOTES:

The gland, rotary holder, and face halves are matched pairs; mixing components from different seals will result in seal failure.

Handle parts carefully. Greasy fingerprints on seal faces or misaligned face splits may cause leakage.

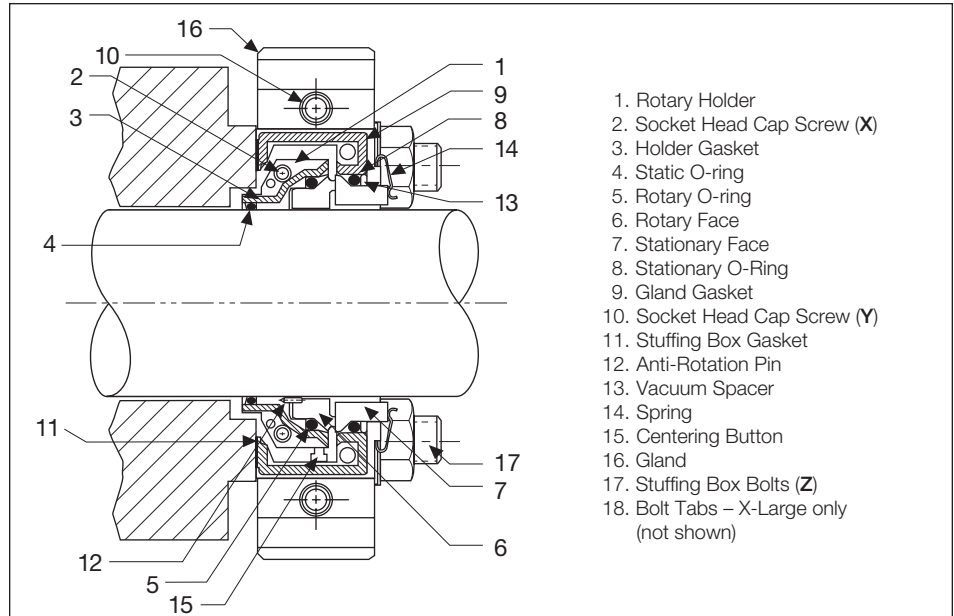

SCREW AND BOLT TORQUE

SEAL SIZE	HOLDER CAP SCREWS* (X)		GLAND CAP SCREWS** (Y)	STUFFING BOX BOLTS** (Z)
up to 2.50" (60 mm)	40 in-lbf (4,5 Nm)	43 in-lbf (4,8 Nm)	125 - 175 in-lbf (14-20 Nm)	15 - 20 ft-lbf (13,5 -27 Nm)
up to 4.75" (120 mm)	100 in-lbf (11,3 Nm)	110 in-lbf (12,4 Nm)	150 - 200 in-lbf (17-23 Nm)	20 - 25 ft-lbf (27-34 Nm)
up to 7.50" (190 mm)	325 in-lbf (36,8 Nm)	325 in-lbf (36,8 Nm)	200 - 300 in-lbf (23-34 Nm)	20 -30 ft-lbf (27-40 Nm)

* Recommended maximum.

** Typical values.

Torque necessary to seat stuffing box gasket varies with bolt size and gasket sealing surfaces.

EQUIPMENT START UP

1. Rotate the shaft by hand to ensure no metal-to-metal contact within the seal. A slight drag may be found due to the seal faces but the shaft should rotate freely.
2. Attach appropriate plumbing to the seal. Take all necessary precautions and follow normal safety procedures before starting the equipment.
3. Depending on how carefully the seal components were handled during installation, split seals may drip on startup. For example, greasy fingerprints on the faces or misaligned face splits may cause leakage. This type of leakage usually

decreases and stops over a period of time as a carbon face wears in or leak paths are sealed. However, leakage greater than 60 drops per minute should be investigated immediately. If the leakage remains steady, check O-rings and gaskets for proper installation and check the faces for chips, scratches, and proper alignment.

INSTALLATION

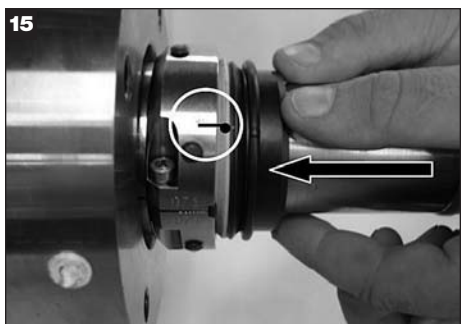
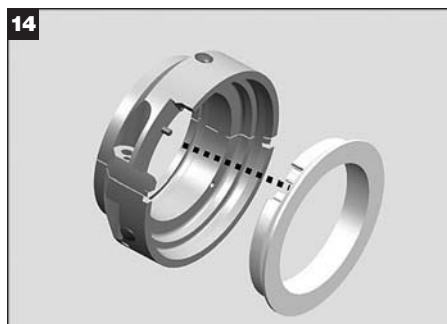
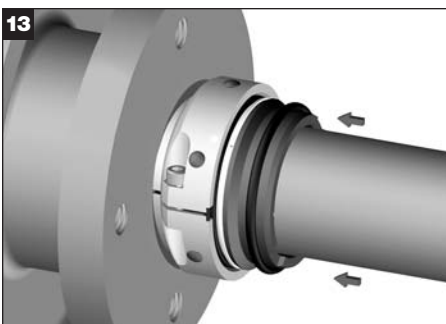
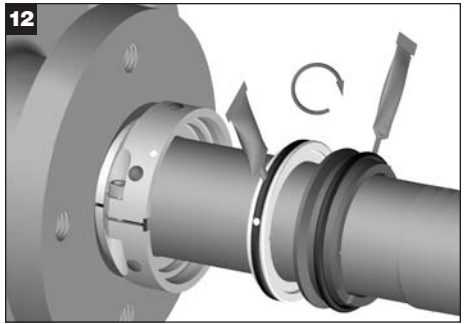
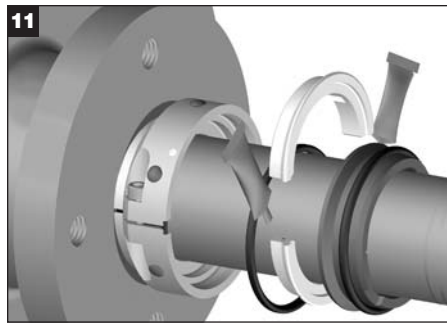
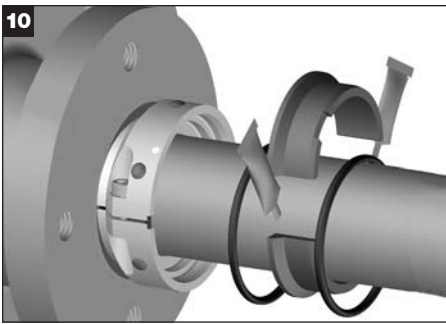
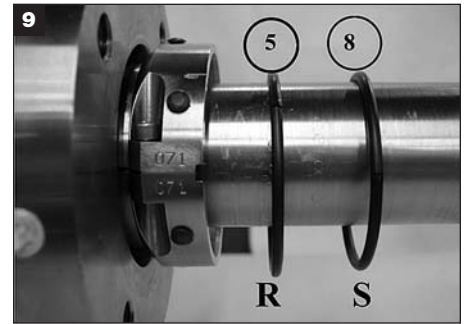
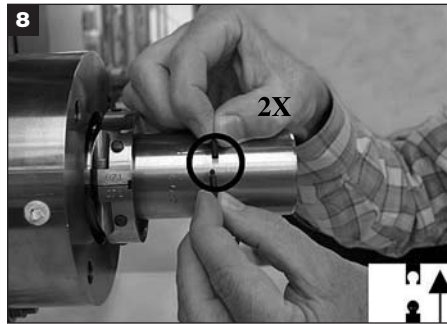
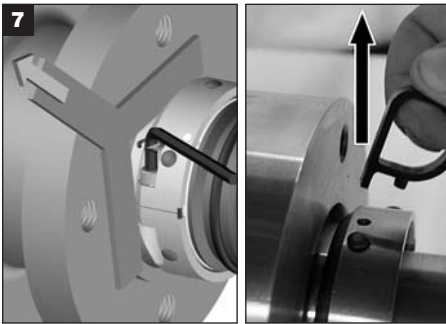
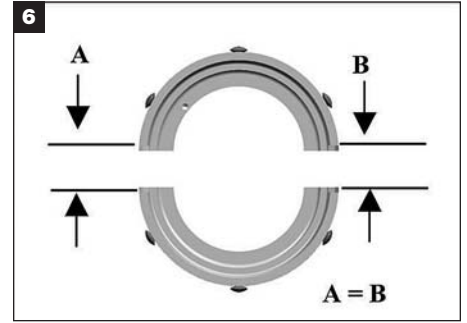
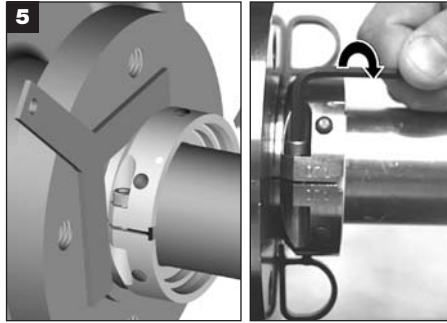
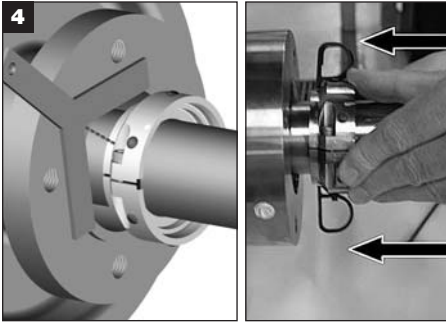
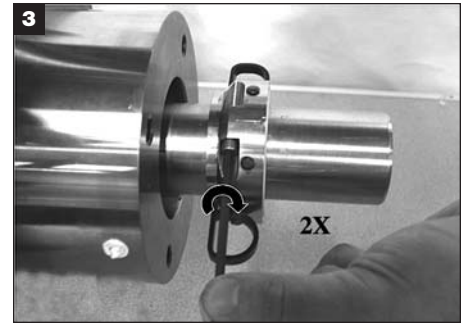
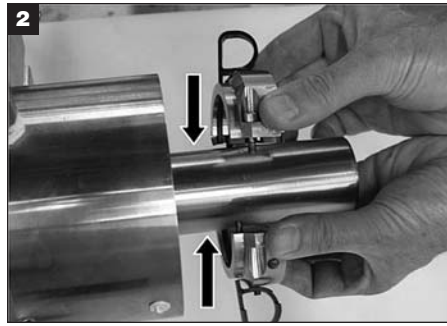

INSTALLATION

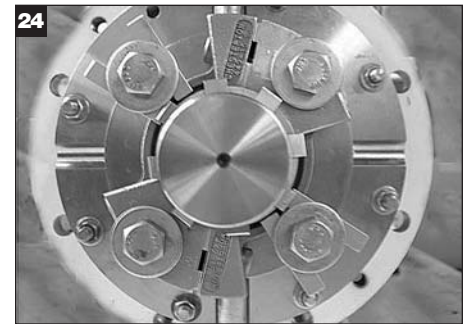
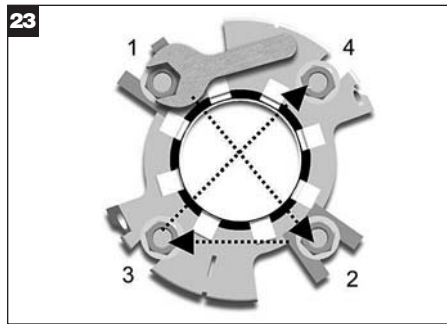
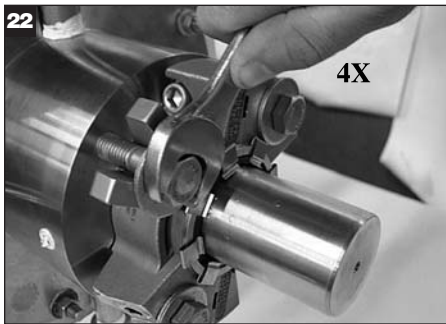
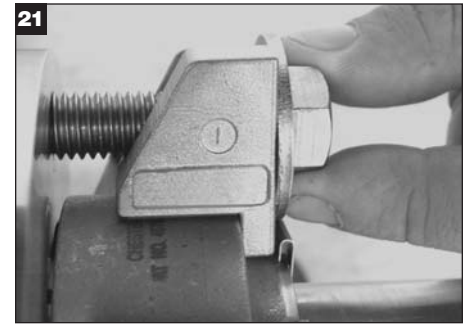
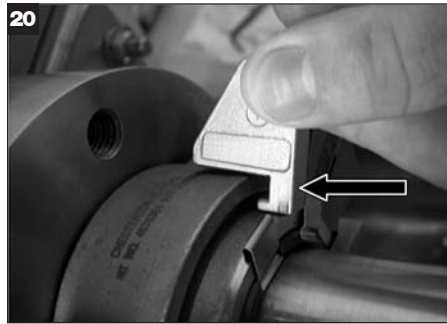
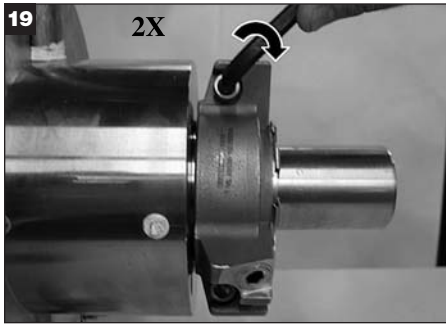
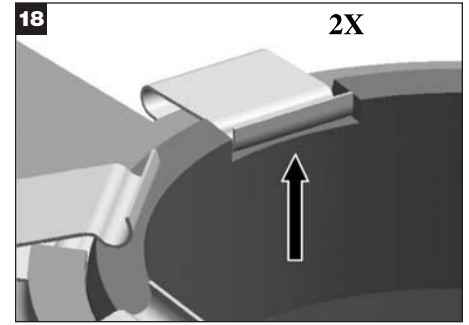
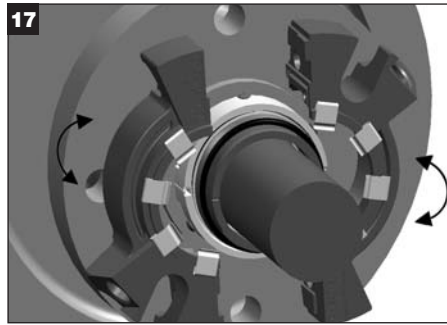
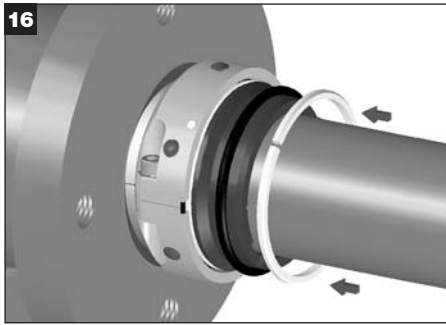

SEAL REBUILD

- Only the gland and rotary holder are reused.
CAUTION: The gland, holder, and face halves are matched pairs; do not mix halves from different seals since this will cause seal failure.
- The following tools may be required for rebuild:
 - Vice grips (remove drive pin)
 - Arbor press (replace drive pin)
 - Blunt thin lever (remove buttons)
 - Rubber mallet (replace buttons and springs)
 - Channel lock pliers (remove springs)
 - Isopropyl alcohol/actone (clean gasket surface)

- Disassemble the seal, noting the condition of the parts. Analyze the cause of failure and correct the problem, if possible, before reinstalling the seal.
- Rebuild of the rotary holder is optional if the shaft O-ring, holder gaskets and drive pin are in good condition.

Seal Size	Drive Pin Protrusion
up to 2 1/2" (60 mm)	0.188" (4,8 mm)
up to 4 3/4" (120 mm)	0.290" (7,4 mm)
up to 7 1/2" (190 mm)	0.435" (11 mm)

- Replacement of springs is optional. Do not replace if springs are in good condition. Ensure all springs are properly seated, and parallel to the back of the gland.
- Remove the stuffing box gasket from the gland face and remove the adhesive residue with isopropyl alcohol or acetone. After peeling off the protective backing, seat the gasket halves in the gland recess, overlapping the gland splits. **Be careful not to wrinkle the gasket as you install it.**

NOTE:
Please see Seal Rebuild images 1 through 18.

SEAL REBUILD

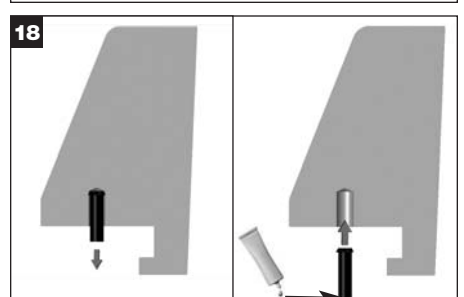
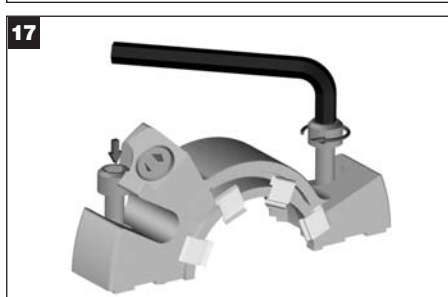
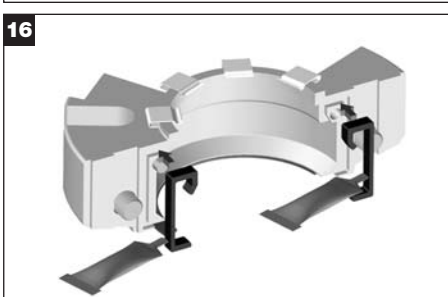
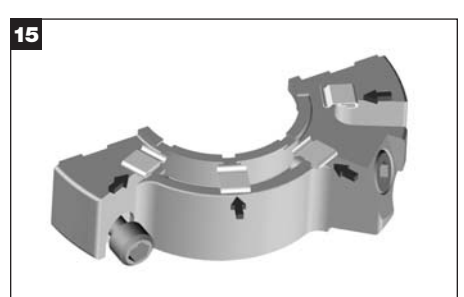
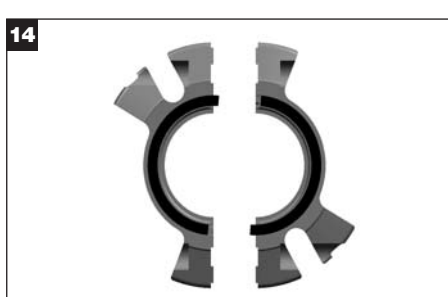
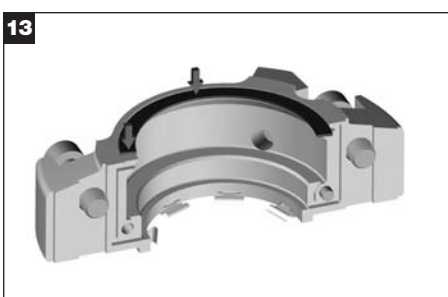
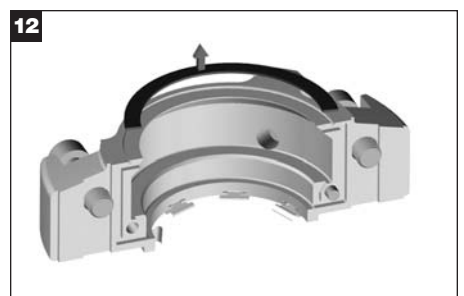
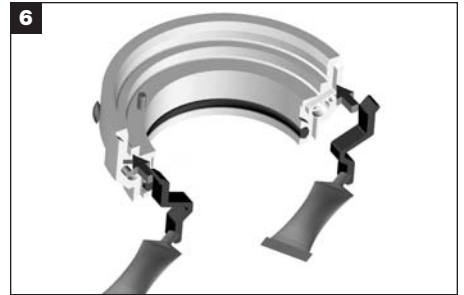
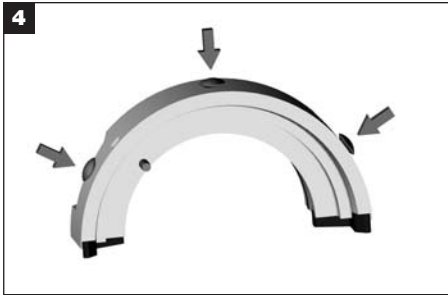
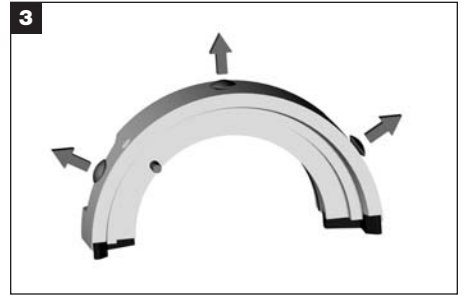

OPERATING CURVES

Radial Motion vs. Pressure Capability
Shaft Sizes: 1.500" to 2.500" (38 mm to 60 mm)

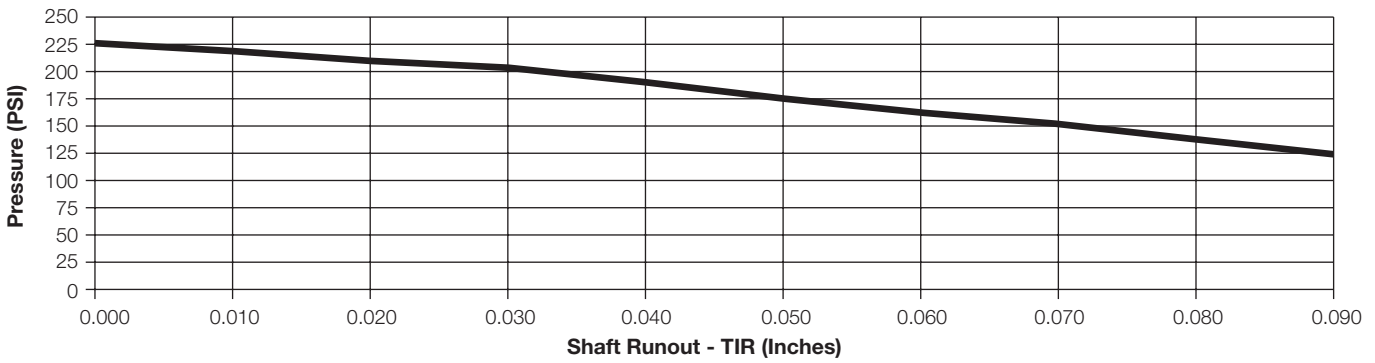

Radial Motion vs. Pressure Capability
Shaft Sizes: 2.625" to 4.750" (65 mm to 120 mm)

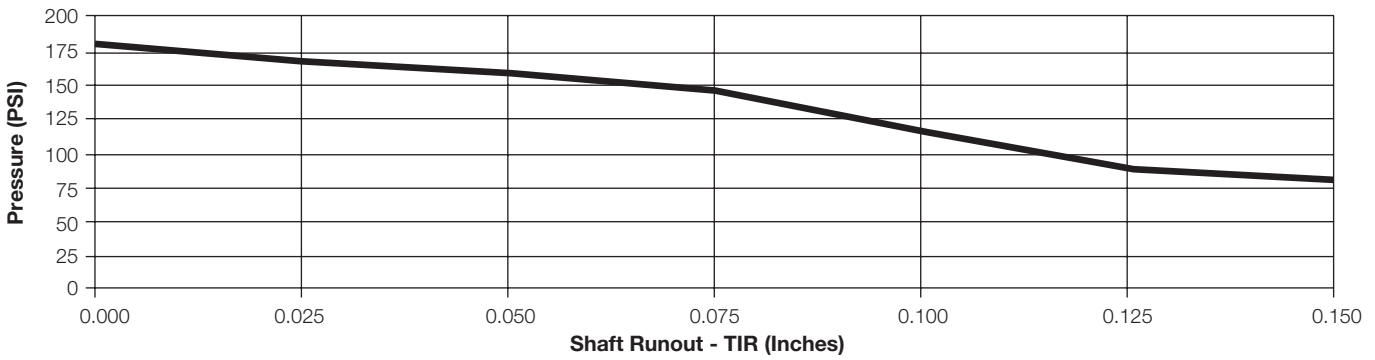

Radial Motion vs. Pressure Capability
Shaft Sizes: 4.875" to 7.500" (125 mm to 190 mm)

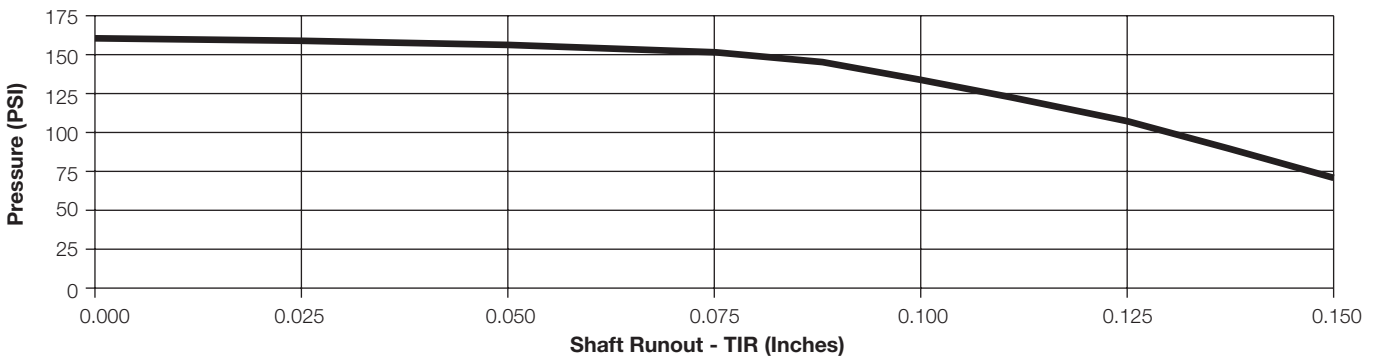

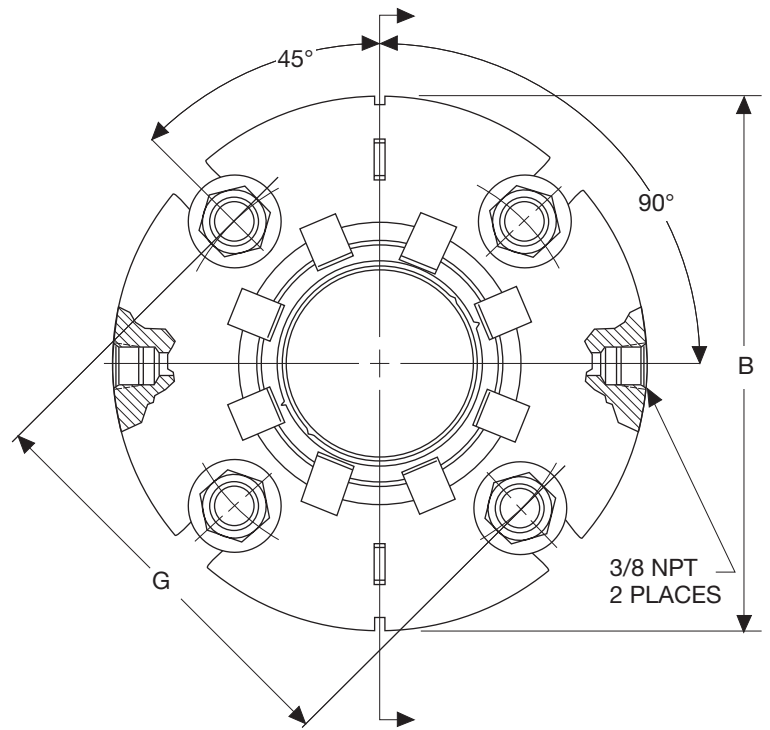
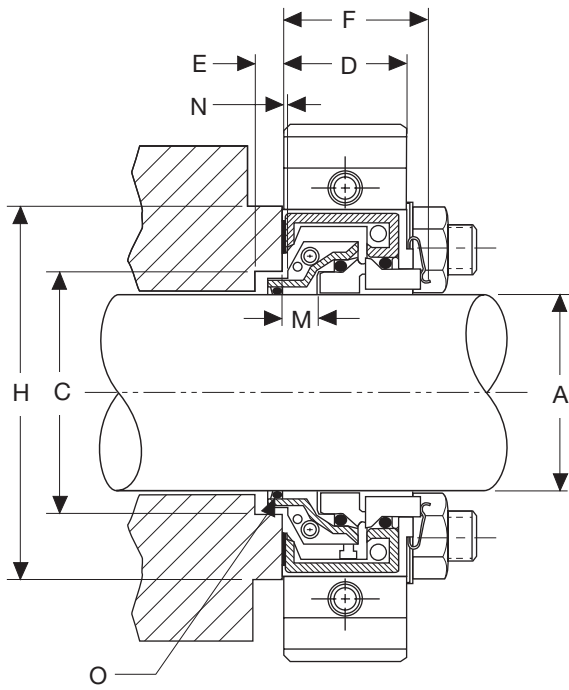

KEY	
A - Shaft Size	G - Minimum Bolt Circle by Bolt Size
B - Maximum Gland Diameter	H - Minimum Stuffing Box Face OD
C - Min./Max. Stuffing Box Diameter	M - Holder ID from Box
D - Gland Length	N - Installation Dimension
E - Minimum Stuffing Box Depth	O - Shaft O-ring Number
F - Outboard Space Required	

DIMENSIONAL DATA (INCH)

Shaft Sizes: 1.500" to 4.750"

A	B MAX	C		D	E MIN	F	G MIN				H MIN	M	N	O O-RING
		MIN	MAX				3/8"	1/2"	5/8"	3/4"				
1.500	5.28	2.11	2.66	1.48	0.17	1.78	3.60	3.73			2.91	0.53	0.094	223
1.625	5.41	2.24	2.77	1.48	0.17	1.78	3.70	3.82			3.00	0.53	0.094	224
1.750	5.53	2.36	2.89	1.48	0.17	1.78	3.82	3.94			3.12	0.53	0.094	225
1.875	5.66	2.49	3.02	1.48	0.17	1.78	3.95	4.07			3.25	0.53	0.094	226
2.000	5.78	2.61	3.16	1.48	0.17	1.78	4.10	4.23	4.35		3.40	0.53	0.094	227
2.125	5.91	2.74	3.28	1.48	0.17	1.78	4.23	4.36	4.48		3.53	0.53	0.094	228
2.250	6.03	2.86	3.42	1.48	0.17	1.78	4.35	4.48	4.60		3.65	0.53	0.094	229
2.375	6.16	2.99	3.71	1.48	0.17	1.78	4.70	4.83	4.95		4.00	0.53	0.094	230
2.500	6.28	3.11	3.71	1.48	0.17	1.78	4.70	4.83	4.95		4.00	0.53	0.094	231
2.625	8.03	3.46	4.53	1.84	0.26	2.24	5.73	5.86	5.98		5.03	0.53	0.094	232
2.750	8.03	3.46	4.53	1.84	0.26	2.24	5.73	5.86	5.98		5.03	0.53	0.094	233
2.875	8.28	3.71	4.78	1.84	0.26	2.24	5.98	6.11	6.23		5.28	0.53	0.094	234
3.000	8.28	3.71	4.78	1.84	0.26	2.24	5.98	6.11	6.23		5.28	0.53	0.094	235
3.125	8.53	3.96	5.03	1.84	0.26	2.24	6.23	6.35	6.48	6.60	5.53	0.53	0.094	236
3.250	8.53	3.96	5.03	1.84	0.26	2.24	6.23	6.35	6.48	6.60	5.53	0.53	0.094	237
3.375	8.78	4.21	5.28	1.84	0.26	2.24	6.48	6.60	6.73	6.85	5.78	0.53	0.094	238
3.500	8.78	4.21	5.28	1.84	0.26	2.24	6.48	6.60	6.73	6.85	5.78	0.53	0.094	239
3.625	9.03	4.46	5.53	1.84	0.26	2.24	6.73	6.85	6.98	7.10	6.03	0.53	0.094	240
3.750	9.03	4.46	5.53	1.84	0.26	2.24	6.73	6.85	6.98	7.10	6.03	0.53	0.094	241
3.875	9.28	4.71	5.78	1.84	0.26	2.24	6.98	7.10	7.23	7.35	6.28	0.53	0.094	242
4.000	9.28	4.71	5.78	1.84	0.26	2.24	6.98	7.10	7.23	7.35	6.28	0.53	0.094	243
4.125	9.53	4.96	6.03	1.84	0.26	2.24	7.23	7.35	7.48	7.60	6.53	0.53	0.094	244
4.250	9.53	4.96	6.03	1.84	0.26	2.24	7.23	7.35	7.48	7.60	6.53	0.53	0.094	245
4.375	9.78	5.21	6.28	1.84	0.26	2.24	7.48	7.60	7.73	7.85	6.78	0.53	0.094	246
4.500	9.78	5.21	6.28	1.84	0.26	2.24	7.48	7.60	7.73	7.85	6.78	0.53	0.094	247
4.625	10.03	5.46	6.28	1.84	0.26	2.24	7.48	7.60	7.73	7.85	6.78	0.53	0.094	248
4.750	10.03	5.46	6.28	1.84	0.26	2.24	7.48	7.60	7.73	7.85	6.78	0.53	0.094	249

DIMENSIONAL DATA (METRIC)

Shaft Sizes: 38 mm to 120 mm

A	B MAX	C		D	E MIN	F	G MIN						H MIN	M	N	O O-RING
		MIN	MAX				8 mm	10 mm	12 mm	14 mm	16 mm	18 mm				
38.0	134.1	53.6	67.4	37.6	4.3	45.2	90.6	92.6	94.6				73.8	13.5	2.4	223
40.0	137.3	56.8	70.2	37.6	4.3	45.2	93.0	95.0	97.0				76.2	13.5	2.4	223
43.0	140.5	60.0	73.4	37.6	4.3	45.2	96.1	98.1	100.1				79.2	13.5	2.4	224
45.0	140.5	60.0	73.4	37.6	4.3	45.2	96.1	98.1	100.1				79.2	13.5	2.4	225
48.0	143.6	63.1	76.6	37.6	4.3	45.2	99.4	101.4	103.4				82.6	13.5	2.4	226
50.0	146.8	66.3	80.3	37.6	4.3	45.2	104.5	106.5	108.5	110.5			86.4	13.5	2.4	226
55.0	150.0	69.5	83.3	37.6	4.3	45.2	107.8	109.8	111.8	113.8			89.7	13.5	2.4	228
60.0	156.3	75.8	94.1	37.6	4.3	45.2	119.7	121.7	123.7	125.7			101.6	13.5	2.4	230
65.0	204.1	87.9	115.1	46.7	6.6	56.9	145.9	147.9	149.9	151.9			127.8	13.5	2.4	231
70.0	204.1	87.9	115.1	46.7	6.6	56.9	145.9	147.9	149.9	151.9			127.8	13.5	2.4	233
75.0	210.4	94.2	121.4	46.7	6.6	56.9	152.2	154.2	156.2	158.2			134.1	13.5	2.4	234
80.0	216.8	100.6	127.8	46.7	6.6	56.9	157.6	159.6	161.6	163.6	165.6	167.6	140.5	13.5	2.4	236
85.0	223.1	106.9	134.1	46.7	6.6	56.9	164.0	166.0	168.0	170.0	172.0	174.0	146.8	13.5	2.4	237
90.0	223.1	106.9	134.1	46.7	6.6	56.9	164.0	166.0	168.0	170.0	172.0	174.0	146.8	13.5	2.4	239
95.0	229.5	113.3	140.5	46.7	6.6	56.9	170.3	172.3	174.3	176.3	178.3	180.3	153.2	13.5	2.4	241
100.0	235.8	119.6	146.8	46.7	6.6	56.9	176.7	178.7	180.7	182.7	184.7	186.7	159.5	13.5	2.4	242
110.0	248.5	132.3	159.5	46.7	6.6	56.9	189.4	191.4	193.4	195.4	197.4	199.4	172.2	13.5	2.4	245
115.0	248.5	132.3	159.5	46.7	6.6	56.9	189.4	191.4	193.4	195.4	197.4	199.4	172.2	13.5	2.4	247
120.0	254.9	138.7	159.5	46.7	6.6	56.9	189.4	191.4	193.4	195.4	197.4	199.4	172.2	13.5	2.4	248

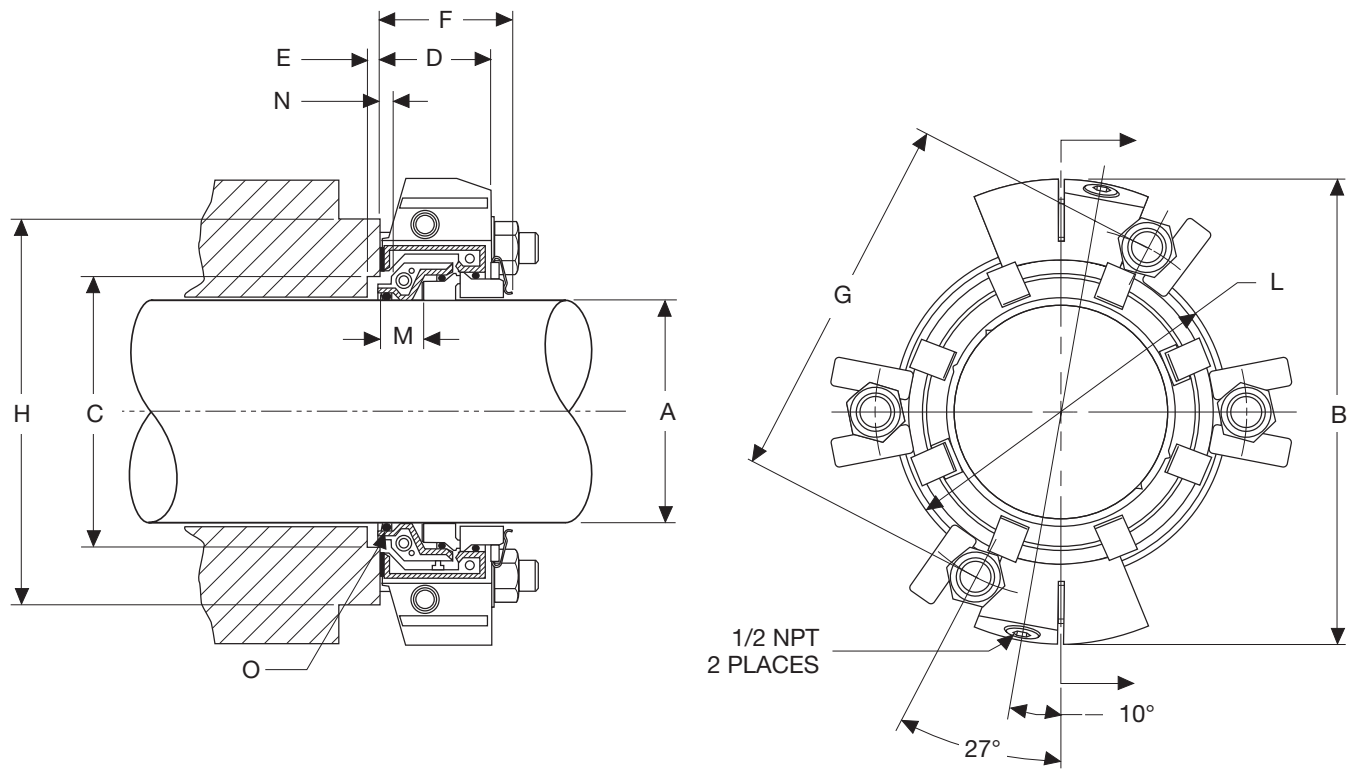

KEY	
A - Shaft Size	G - Minimum Bolt Circle by Bolt Size
B - Maximum Gland Diameter	H - Minimum Stuffing Box Face OD
C - Min./Max. Stuffing Box Diameter	L - Gland Hub OD
D - Gland Length	M - Holder ID from Box
E - Minimum Stuffing Box Depth	N - Installation Dimension
F - Outboard Space Required	O - Shaft O-ring Number

DIMENSIONAL DATA (INCH)

Shaft Sizes: 4.875" to 7.500"

A	B MAX	C		D	E MIN	F	G MIN			H MIN	L MAX	M	N	O O-RING
		MIN	MAX				5/8"	3/4"	7/8"					
		4.875	11.53				5.93	7.15	2.91					
5.000	11.53	6.05	7.15	2.91	0.29	3.45	8.63	8.75	8.88	7.75	7.99	1.03	0.188	354
5.125	11.78	6.18	7.40	2.91	0.29	3.45	8.88	9.00	9.13	8.00	8.24	1.03	0.188	355
5.250	11.78	6.30	7.40	2.91	0.29	3.45	8.88	9.00	9.13	8.00	8.24	1.03	0.188	356
5.375	12.03	6.43	7.65	2.91	0.29	3.45	9.13	9.25	9.38	8.25	8.49	1.03	0.188	357
5.500	12.03	6.55	7.65	2.91	0.29	3.45	9.13	9.25	9.38	8.25	8.49	1.03	0.188	358
5.625	12.28	6.68	7.90	2.91	0.29	3.45	9.38	9.50	9.63	8.50	8.74	1.03	0.188	359
5.750	12.28	6.80	7.90	2.91	0.29	3.45	9.38	9.50	9.63	8.50	8.74	1.03	0.188	360
5.875	12.53	6.93	8.15	2.91	0.29	3.45	9.63	9.75	9.88	8.75	8.99	1.03	0.188	361
6.000	12.53	7.05	8.15	2.91	0.29	3.45	9.63	9.75	9.88	8.75	8.99	1.03	0.188	362
6.125	12.78	7.18	8.40	2.91	0.29	3.45	9.88	10.00	10.13	9.00	9.25	1.03	0.188	362
6.250	12.78	7.30	8.40	2.91	0.29	3.45	9.88	10.00	10.13	9.00	9.25	1.03	0.188	363
6.375	13.03	7.43	8.65	2.91	0.29	3.45	10.13	10.25	10.38	9.25	9.50	1.03	0.188	363
6.500	13.03	7.55	8.65	2.91	0.29	3.45	10.13	10.25	10.38	9.25	9.50	1.03	0.188	364
6.625	13.29	7.68	8.90	2.91	0.29	3.45	10.38	10.50	10.63	9.50	9.75	1.03	0.188	364
6.750	13.29	7.80	8.90	2.91	0.29	3.45	10.38	10.50	10.63	9.50	9.75	1.03	0.188	365
6.875	13.54	7.93	9.15	2.91	0.29	3.45	10.63	10.75	10.88	9.75	10.00	1.03	0.188	365
7.000	13.54	8.05	9.15	2.91	0.29	3.45	10.63	10.75	10.88	9.75	10.00	1.03	0.188	366
7.125	13.79	8.18	9.40	2.91	0.29	3.45	10.88	11.00	11.13	10.00	10.25	1.03	0.188	366
7.250	13.79	8.30	9.40	2.91	0.29	3.45	10.88	11.00	11.13	10.00	10.25	1.03	0.188	367
7.375	14.04	8.43	9.65	2.91	0.29	3.45	11.13	11.25	11.38	10.25	10.50	1.03	0.188	367
7.500	14.04	8.55	9.65	2.91	0.29	3.45	11.13	11.25	11.38	10.25	10.50	1.03	0.188	368

DIMENSIONAL DATA (METRIC)

Shaft Sizes: 125 mm to 190 mm

A	B MAX	C		D	E MIN	F	G MIN			H MIN	L MAX	M	N	O O-RING
		MIN	MAX				18 mm	20 mm	22 mm					
		125.0	292.8				153.7	181.6	73.9					
130.0	299.2	156.8	188.0	73.9	7.4	87.6	227.8	229.8	231.8	203.2	209.3	26.2	4.8	355
135.0	305.6	163.2	194.3	73.9	7.4	87.6	234.1	236.1	238.1	209.6	215.7	26.2	4.8	356
140.0	305.6	166.4	194.3	73.9	7.4	87.6	234.1	236.1	238.1	209.6	215.7	26.2	4.8	358
145.0	312.0	172.7	200.7	73.9	7.4	87.6	240.5	242.5	244.5	215.9	222.1	26.2	4.8	359
150.0	318.3	179.1	207.0	73.9	7.4	87.6	246.8	248.8	250.8	222.3	228.4	26.2	4.8	361
155.0	324.7	182.2	213.4	73.9	7.4	87.6	253.2	255.2	257.2	228.6	234.8	26.2	4.8	362
160.0	331.1	188.6	219.7	73.9	7.4	87.6	259.5	261.5	263.5	235.0	241.2	26.2	4.8	363
165.0	331.1	191.8	219.7	73.9	7.4	87.6	259.5	261.5	263.5	235.0	241.2	26.2	4.8	364
170.0	337.5	198.1	226.1	73.9	7.4	87.6	265.9	267.9	269.9	241.3	247.6	26.2	4.8	364
175.0	343.9	201.3	232.4	73.9	7.4	87.6	272.2	274.2	276.2	247.7	254.0	26.2	4.8	365
180.0	350.2	207.6	238.8	73.9	7.4	87.6	278.6	280.6	282.6	254.0	260.4	26.2	4.8	366
185.0	350.2	210.8	238.8	73.9	7.4	87.6	278.6	280.6	282.6	254.0	260.4	26.2	4.8	367
190.0	356.6	217.2	245.1	73.9	7.4	87.6	284.9	286.9	288.9	260.4	266.8	26.2	4.8	368

442MT2 is a trademark of A.W. Chesterton Company.



860 Salem Street
 Groveland, MA 01834 USA
 Telephone: 781-438-7000 Fax: 978-469-6528
 www.chesterton.com

ISO Certifications available at www.chesterton.com/corporate/iso

© A.W. Chesterton Company, 2007. All rights reserved.
 ® Registered trademark owned and licensed by
 A.W. Chesterton Company in USA and other countries.

FORM NO. 072957 REV. 6

PRINTED IN USA 05/07