

442™ Installation Instructions

EQUIPMENT PREPARATION

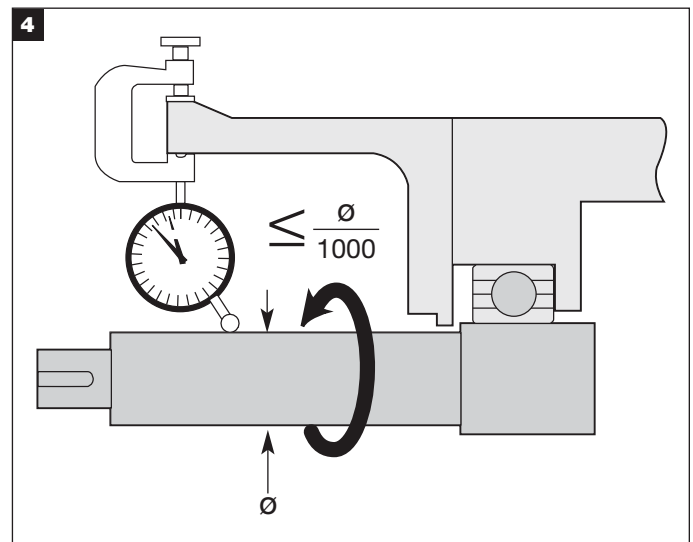
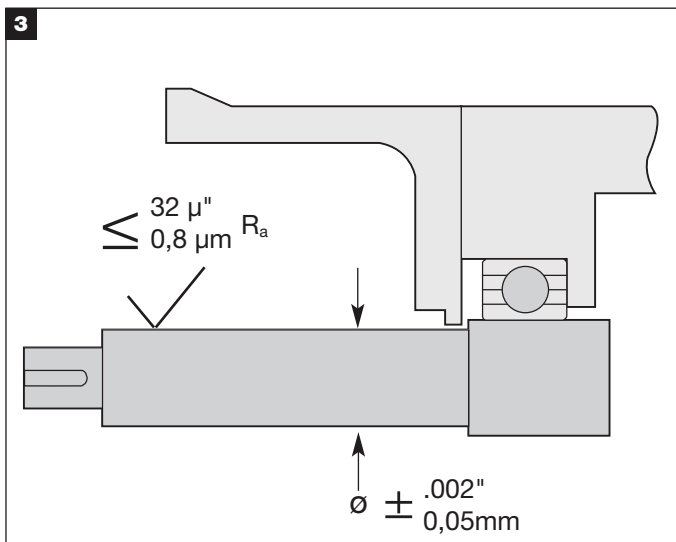
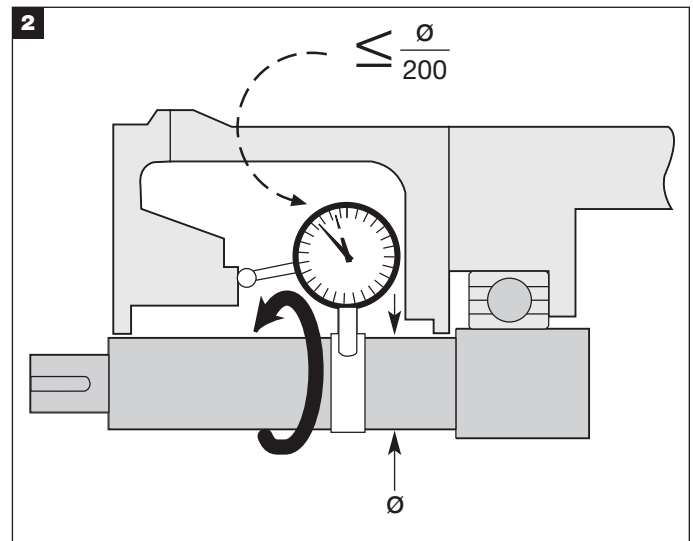
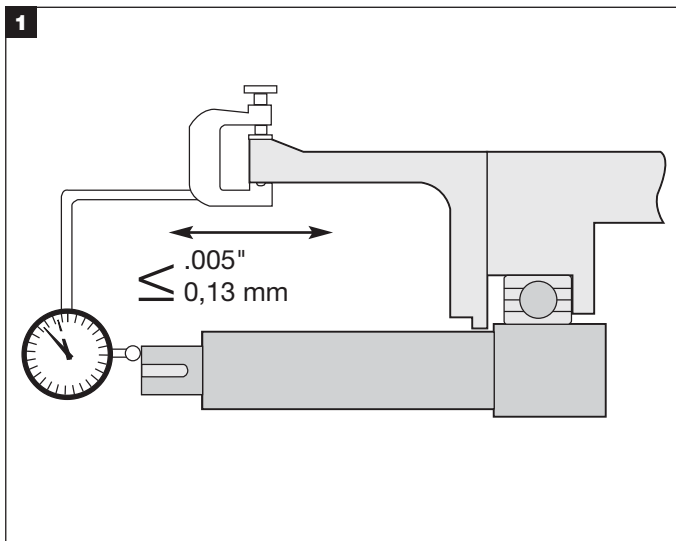

CAUTIONS

These instructions are general in nature. It is assumed that the installer is familiar with seals and certainly with the requirements of their plant for the successful use of mechanical seals. If in doubt, get assistance from someone in the plant who is familiar with seals or delay the installation until a seal representative is available. All necessary auxiliary

arrangements for successful operation (heating, cooling, flushing) as well as safety devices must be employed. These decisions are to be made by the user. The chemical listing is intended as a **general** reference for this seal **only**. The decision to use this seal or any other Chesterton seal in a particular service is the customer's responsibility.

SEAL PREPARATION

Please read these instructions and make sure you understand them before installing the seal.

Installation is easy provided the parts are handled and installed carefully. Make sure your hands are clean. Any dirt particles on the seal faces or splits during handling may cause seal failure. Prepare a clean work surface on which to place parts during assembly/disassembly.

Prepare the Seal for Installation (1-6)

1. Disengage the socket head cap screws from one half of the gland. With the gland in a horizontal position, springs up, separate the halves and place them on the clean work surface.
2. You now have access to the rotary holder. Disengage the two socket head cap screws from one half of the rotary holder and place the holder halves on the clean work surface.
3. Remove the rotary and stationary seal faces from their packages and place on the clean work surface.
4. Make sure that the gland gaskets, holder gaskets and shaft O-ring are properly greased and seated in their grooves. Note the gold mark on one end of each half of the cut static O-ring. Assure that the O-ring is placed in the rotary holder such that the two gold marks mate at one joint. **Do not glue the gland or holder gaskets in place.**
5. Snap open the ball and socket joint of the O-rings by pulling at the seam. (NOTE: The rotary O-ring is slightly longer and is marked with a purple dot.) **Do not apply grease or glue to the balls and sockets of the O-rings.**
6. Install seal per instructions (pages 3 and 4).

NOTES:

The gland, rotary holder, and face halves are matched pairs; mixing components from different seals will result in seal failure.

Handle parts carefully. Greasy fingerprints on seal faces or misaligned face splits may cause leakage.

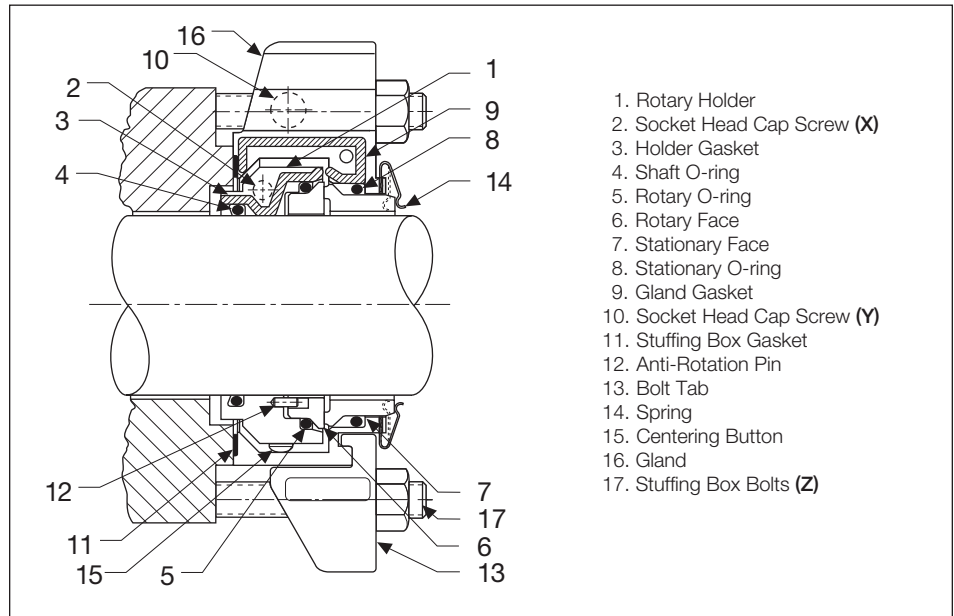

SCREW AND BOLT TORQUE

SEAL SIZE	HOLDER CAP SCREWS* (X)		GLAND CAP SCREWS** (Y)	STUFFING BOX BOLTS** (Z)
up to 2.50" (60 mm)	40 in-lbf (4,5 Nm)	43 in-lbf (4,8 Nm)	125 - 175 in-lbf (14-20 Nm)	15 - 20 ft-lbf (13,5 -27 Nm)
up to 4.75" (120 mm)	100 in-lbf (11,3 Nm)	110 in-lbf (12,4 Nm)	150 - 200 in-lbf (17-23 Nm)	20 - 25 ft-lbf (27-34 Nm)
up to 7.75" (195 mm)	325 in-lbf (36,8 Nm)	325 in-lbf (36,8 Nm)	200 - 300 in-lbf (23-34 Nm)	20 -30 ft-lbf (27-40 Nm)

* Recommended maximum.

** Typical values.

Torque necessary to seat stuffing box gasket varies with bolt size and gasket sealing surfaces.

EQUIPMENT START UP

1. Rotate the shaft by hand to ensure no metal-to-metal contact within the seal. A slight drag may be found due to the seal faces but the shaft should rotate freely.
2. Attach appropriate plumbing to the seal. Take all necessary precautions and follow normal safety procedures before starting the equipment.
3. Depending on how carefully the seal components were handled during installation, split seals

may drip on startup. For example, greasy fingerprints on the faces or misaligned face splits may cause leakage. This type of leakage usually decreases and stops over a period of time as a carbon face wears in or leak paths are sealed. If the leakage remains steady, check O-rings and gaskets for proper installation and check the faces for chips, scratches, and proper alignment.

INSTALLATION

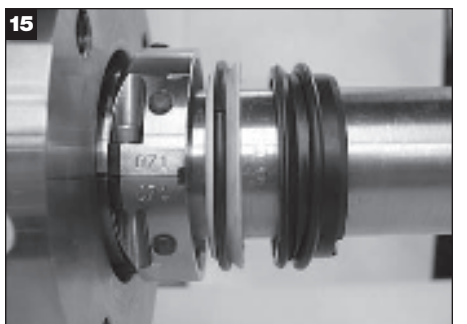
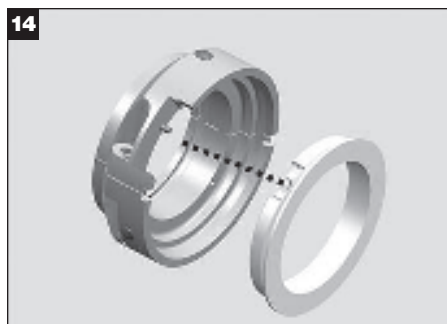
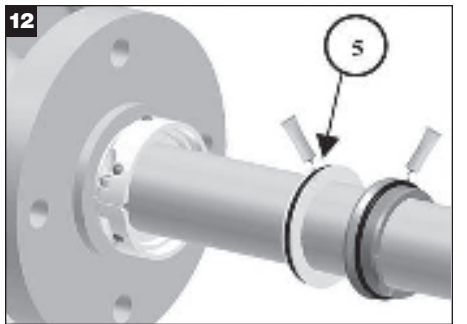
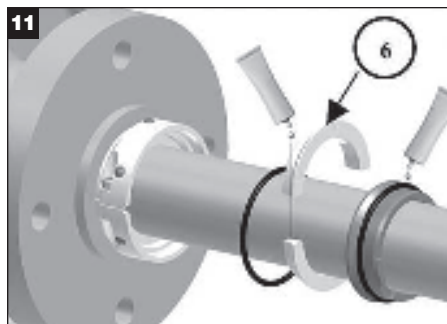
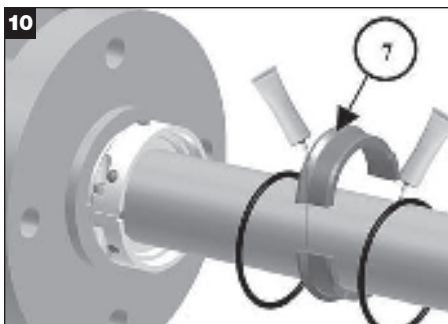
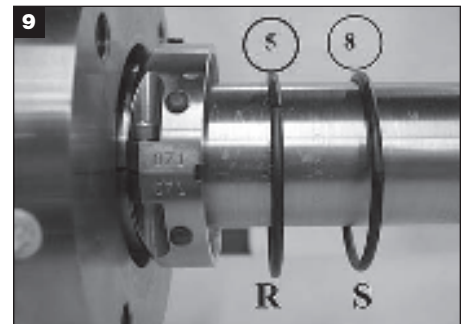
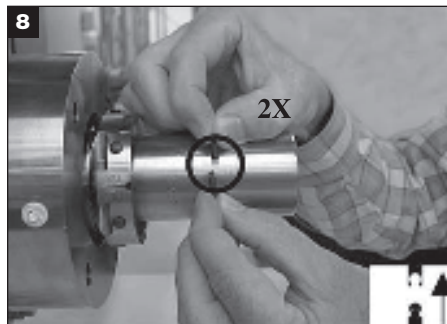
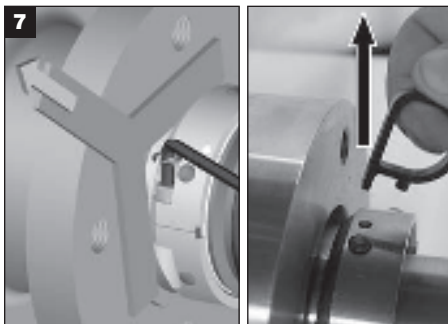
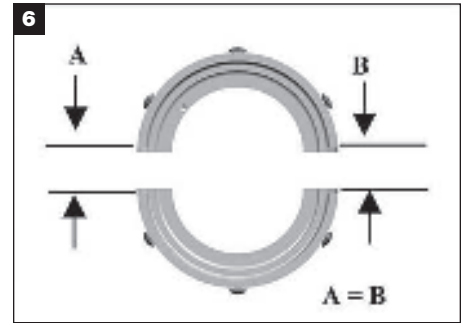
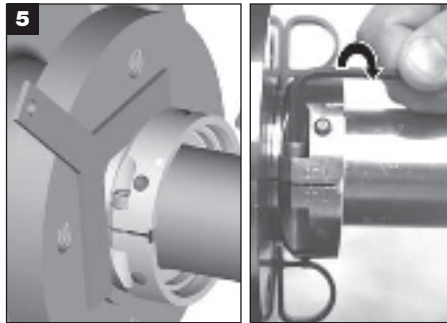
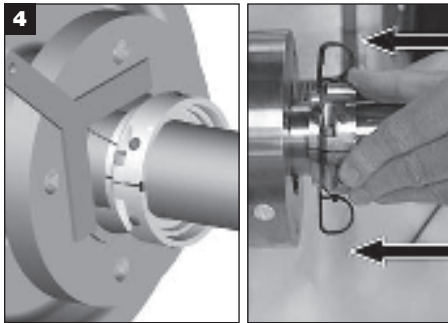
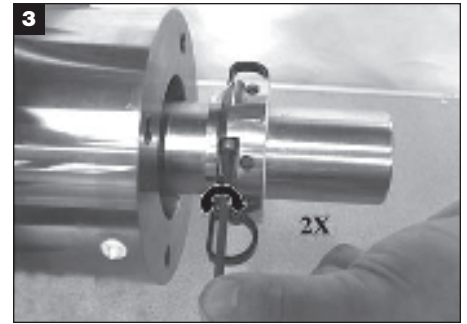
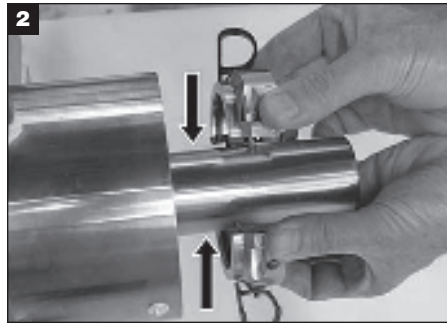

INSTALLATION

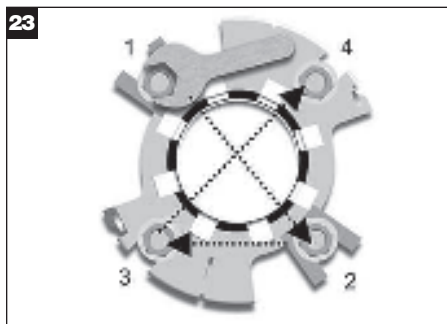
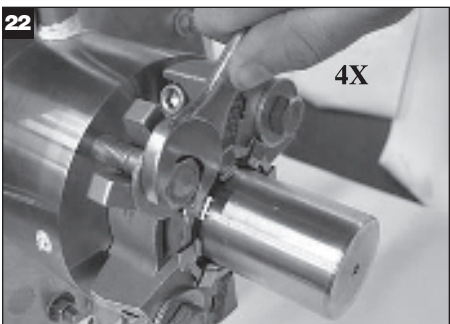
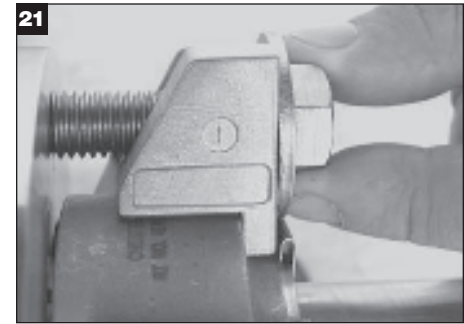
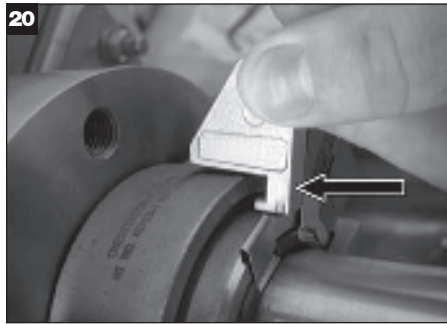
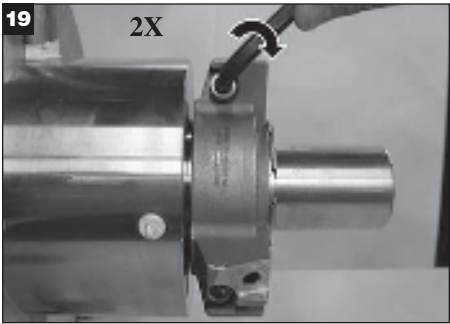
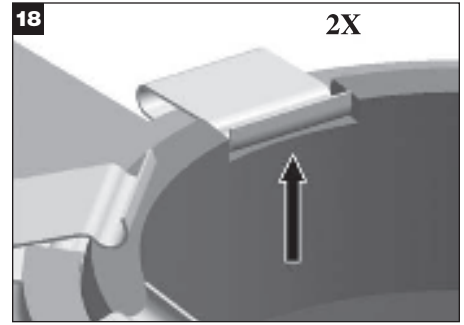
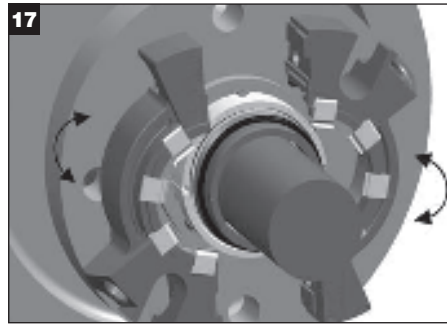
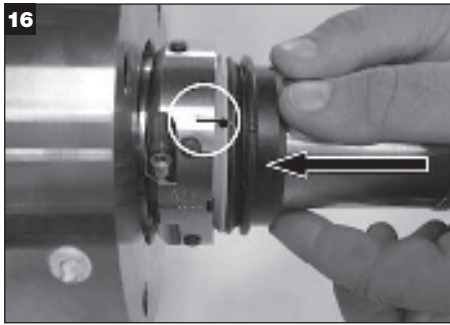

SEAL REBUILD

1. Only the gland and rotary holder are reused.

CAUTION: The gland, holder, and face halves are matched pairs; do not mix halves from different seals since this will cause seal failure.

2. The following tools may be required for rebuild:

- Vice grips (remove drive pin)
- Arbor press (replace drive pin)
- Blunt thin lever (remove buttons)
- Rubber mallet (replace buttons and springs)
- Channel lock pliers (remove springs)
- Isopropyl alcohol/acetone (clean gasket surface)

3. Disassemble the seal, noting the condition of the parts. Analyze the cause of failure and correct the problem, if possible, before reinstalling the seal.

4. Rebuild of the rotary holder is optional if the shaft O-ring, holder gaskets and drive pin are in good condition.

Seal Size	Drive Pin Protrusion
up to 2 1/2" (60 mm)	0.188" (4,8 mm)
up to 4 3/4" (120 mm)	0.290" (7,4 mm)
up to 7 3/4" (195 mm)	0.435" (11 mm)

5. Replacement of springs is optional. Do not replace if springs are in good condition. Ensure all springs are properly seated, and parallel to the back of the gland.

6. Remove the stuffing box gasket from the gland face and remove the adhesive residue with isopropyl alcohol or acetone. After peeling off the protective backing, seat the gasket halves in the gland recess, overlapping the gland splits. **Be careful not to wrinkle the gasket as you install it.**

NOTE:
Please see Seal Rebuild images 1 through 18.

SEAL REBUILD

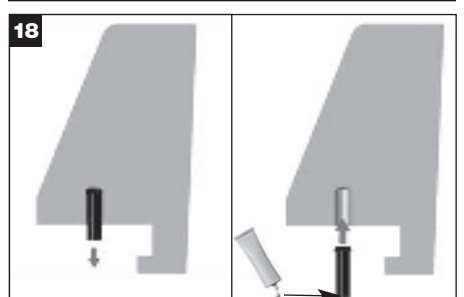
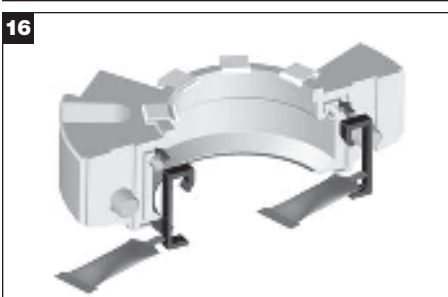
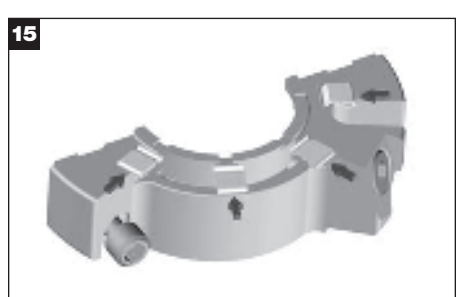
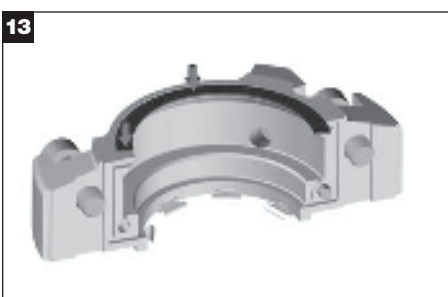
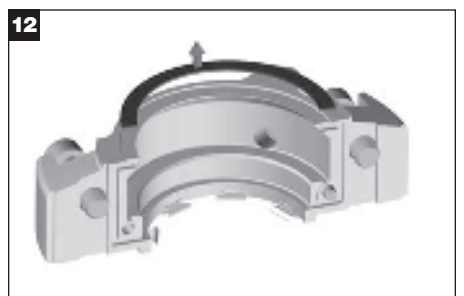
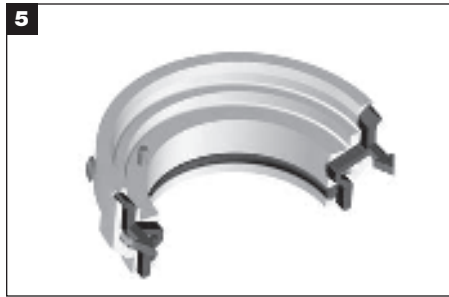
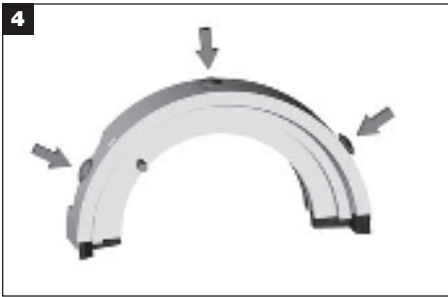
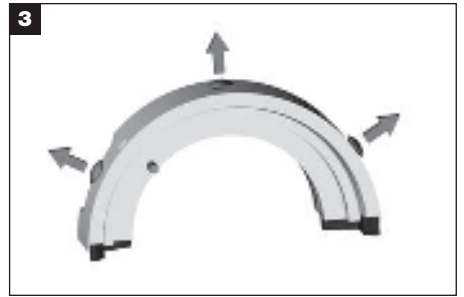

DIMENSIONAL DATA (DRAWINGS)

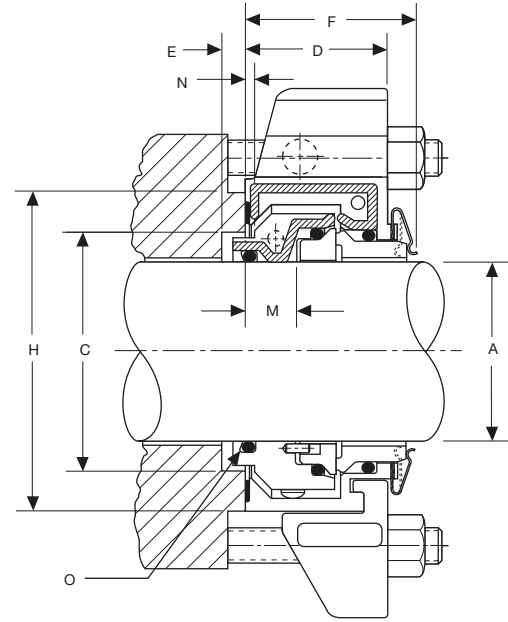
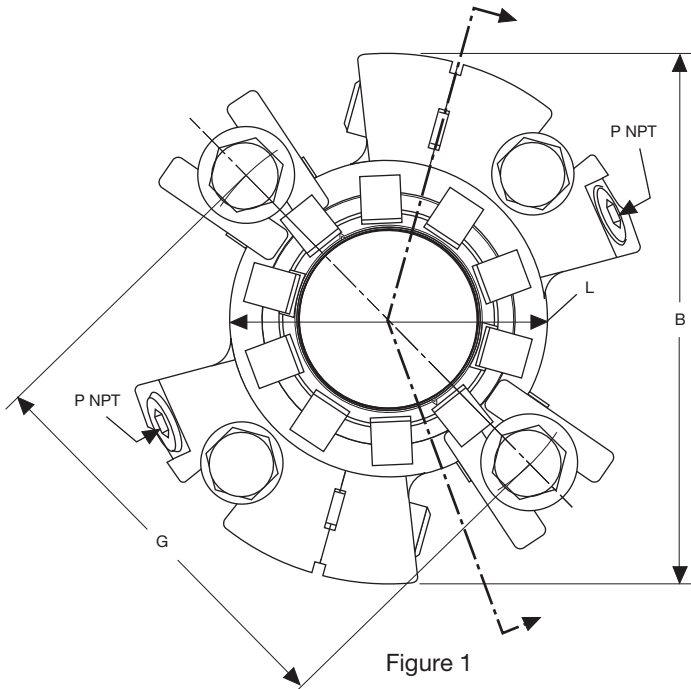

EQUIPMENT BOLT PATTERNS

Shaft Sizes: 1.625" to 4.750" (40 mm to 120 mm)

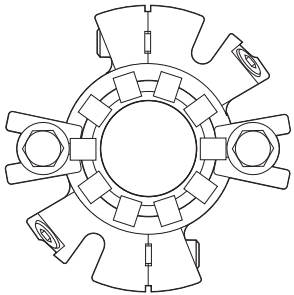

2 BOLTS

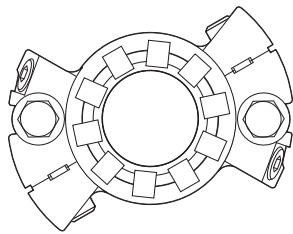

2 BOLTS

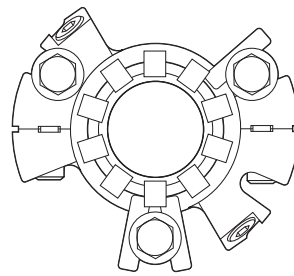

3 BOLTS

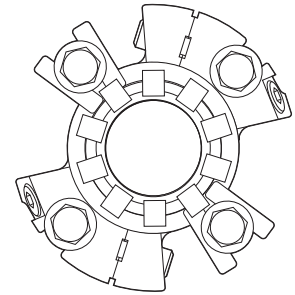

4 BOLTS

All Other Shaft Sizes

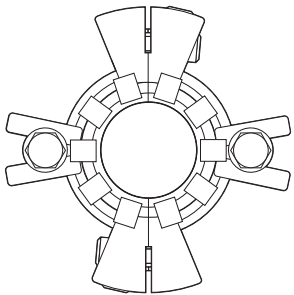

2 BOLTS

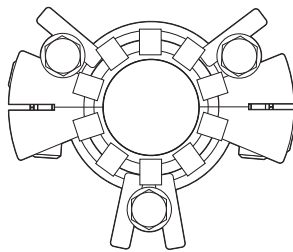

3 BOLTS

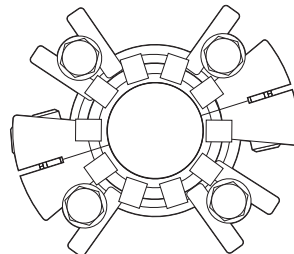

4 BOLTS

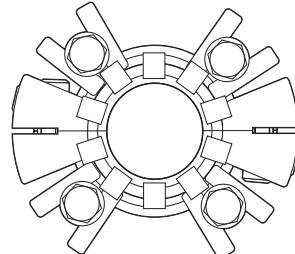

4 BOLTS

DIMENSIONAL DATA (INCH)

A	B MAX	C		D	E MIN	F	G MIN					H MIN	L MAX	O O-RING
		MIN	MAX				3/8"	1/2"	5/8"	3/4"	7/8"			
1.250	4.94	1.86	2.10	1.48	0.17	1.78	3.20	3.33	3.45	-	-	2.35	2.79	-219
1.375	5.02	1.94	2.38	1.48	0.17	1.78	3.28	3.40	3.53	-	-	2.63	2.87	-221
1.500	5.14	2.06	2.50	1.48	0.17	1.78	3.40	3.53	3.65	-	-	2.75	2.99	-223
1.625	5.26	2.19	2.63	1.48	0.17	1.78	3.50	3.63	-	-	-	2.87	3.11	-224
1.750	5.39	2.31	2.75	1.48	0.17	1.78	3.63	3.75	-	-	-	3.00	3.23	-225
1.875	5.51	2.44	2.88	1.48	0.17	1.78	3.75	3.88	-	-	-	3.12	3.35	-226
2.000	5.64	2.56	3.00	1.48	0.17	1.78	3.94	4.06	-	-	-	3.25	3.48	-227
2.125	5.76	2.69	3.12	1.48	0.17	1.78	4.06	4.19	4.31	-	-	3.37	3.60	-228
2.250	5.88	2.81	3.25	1.48	0.17	1.78	4.19	4.31	4.44	-	-	3.50	3.73	-229
2.375	6.01	2.94	3.37	1.48	0.17	1.78	4.31	4.43	4.56	-	-	3.62	3.85	-230
2.500	6.13	3.06	3.75	1.48	0.17	1.78	4.57	4.70	4.82	-	-	4.00	4.23	-231
2.625	7.77	3.35	4.25	1.84	0.26	2.24	5.44	5.56	5.69	-	-	4.75	5.00	-232
2.750	7.77	3.35	4.25	1.84	0.26	2.24	5.44	5.56	5.69	-	-	4.75	5.00	-233
2.875	8.02	3.60	4.50	1.84	0.26	2.24	5.66	5.78	5.91	-	-	5.00	5.25	-234
3.000	8.02	3.60	4.50	1.84	0.26	2.24	5.66	5.78	5.91	-	-	5.00	5.25	-235
3.125	8.27	3.85	4.75	1.84	0.26	2.24	6.00	6.12	6.25	-	-	5.25	5.49	-236
3.250	8.27	3.85	4.75	1.84	0.26	2.24	6.00	6.12	6.25	-	-	5.25	5.49	-237
3.375	8.51	4.10	5.00	1.84	0.26	2.24	6.16	6.28	6.41	6.53	6.66	5.50	5.75	-238
3.500	8.51	4.10	5.00	1.84	0.26	2.24	6.16	6.28	6.41	6.53	6.66	5.50	5.75	-239
3.625	8.77	4.35	5.25	1.84	0.26	2.24	6.41	6.53	6.66	6.78	6.91	5.75	6.00	-240
3.750	8.77	4.35	5.25	1.84	0.26	2.24	6.41	6.53	6.66	6.78	6.91	5.75	6.00	-241
3.875	9.02	4.60	5.50	1.84	0.26	2.24	6.66	6.78	6.91	7.03	7.16	6.00	6.25	-242
4.000	9.02	4.60	5.50	1.84	0.26	2.24	6.66	6.78	6.91	7.03	7.16	6.00	6.25	-243
4.125	9.27	4.85	5.75	1.84	0.26	2.24	6.91	7.03	7.16	7.28	7.41	6.25	6.50	-244
4.250	9.27	4.85	5.75	1.84	0.26	2.24	6.91	7.03	7.16	7.28	7.41	6.25	6.50	-245
4.375	9.52	5.10	6.00	1.84	0.26	2.24	7.16	7.28	7.41	7.53	7.66	6.50	6.75	-246
4.500	9.52	5.10	6.00	1.84	0.26	2.24	7.16	7.28	7.41	7.53	7.66	6.50	6.75	-247
4.625	9.77	5.35	6.25	1.84	0.26	2.24	7.41	7.53	7.66	7.78	7.91	6.75	7.00	-248
4.750	9.77	5.35	6.25	1.84	0.26	2.24	7.41	7.53	7.66	7.78	7.91	6.75	7.00	-249
4.875	11.28	5.87	7.00	2.91	0.29	3.45	-	-	8.41	8.53	8.66	7.50	7.74	-353
5.000	11.28	5.99	7.00	2.91	0.29	3.45	-	-	8.41	8.53	8.66	7.50	7.74	-354
5.125	11.53	6.12	7.25	2.91	0.29	3.45	-	-	8.66	8.78	8.91	7.75	7.99	-355
5.250	11.53	6.24	7.25	2.91	0.29	3.45	-	-	8.66	8.78	8.91	7.75	7.99	-356
5.375	11.78	6.37	7.50	2.91	0.29	3.45	-	-	8.91	9.03	9.16	8.00	8.24	-357
5.500	11.78	6.49	7.50	2.91	0.29	3.45	-	-	8.91	9.03	9.16	8.00	8.24	-358
5.625	12.03	6.62	7.75	2.91	0.29	3.45	-	-	9.16	9.28	9.41	8.25	8.49	-359
5.750	12.03	6.74	7.75	2.91	0.29	3.45	-	-	9.16	9.28	9.41	8.25	8.49	-360
5.875	12.28	6.87	8.00	2.91	0.29	3.45	-	-	9.41	9.54	9.66	8.50	8.74	-361
6.000	12.28	6.99	8.00	2.91	0.29	3.45	-	-	9.41	9.54	9.66	8.50	8.74	-362
6.125	12.53	7.12	8.25	2.91	0.29	3.45	-	-	9.66	9.79	9.91	8.75	8.99	-362
6.250	12.53	7.24	8.25	2.91	0.29	3.45	-	-	9.66	9.79	9.91	8.75	8.99	-363
6.375	12.78	7.37	8.50	2.91	0.29	3.45	-	-	9.91	10.04	10.16	9.00	9.25	-363
6.500	12.78	7.49	8.50	2.91	0.29	3.45	-	-	9.91	10.04	10.16	9.00	9.25	-364
6.625	13.03	7.62	8.75	2.91	0.29	3.45	-	-	10.17	10.29	10.42	9.25	9.50	-364
6.750	13.03	7.74	8.75	2.91	0.29	3.45	-	-	10.17	10.29	10.42	9.25	9.50	-365
6.875	13.28	7.87	9.00	2.91	0.29	3.45	-	-	10.42	10.54	10.67	9.50	9.75	-365
7.000	13.28	7.99	9.00	2.91	0.29	3.45	-	-	10.42	10.54	10.67	9.50	9.75	-366
7.125	13.53	8.12	9.25	2.91	0.29	3.45	-	-	10.67	10.79	10.92	9.75	10.00	-366
7.250	13.53	8.24	9.25	2.91	0.29	3.45	-	-	10.67	10.79	10.92	9.75	10.00	-367
7.375	13.78	8.37	9.50	2.91	0.29	3.45	-	-	10.92	11.04	11.17	10.00	10.25	-367
7.500	13.78	8.49	9.50	2.91	0.29	3.45	-	-	10.92	11.04	11.17	10.00	10.25	-368
7.625	14.03	8.62	9.75	2.91	0.29	3.45	-	-	11.17	11.29	11.42	10.25	10.50	-368
7.750	14.03	8.74	9.75	2.91	0.29	3.45	-	-	11.17	11.29	11.42	10.25	10.50	-369

DIMENSIONAL DATA (INCH & METRIC)

SHAFT SIZE	M HOLDER ID FROM BOX		N INSTALLATION DIM		P NPT SIZE
	INCH	METRIC	INCH	METRIC	
1.250" to 1.500" (32 mm to 38 mm)	0.53	13,5	0.094	2,4	1/4"
1.625" to 4.750" (40 mm to 120 mm)	0.53	13,5	0.094	2,4	3/8"
4.875" to 7.750" (125 mm to 195 mm)	1.03	26,0	0.188	4,8	1/2"

KEY - Figures 1 & 2

A – Shaft Size	H – Min. Stuffing Box Face OD
B – Max. Gland Dia.	L – Gland Hub OD
C – Min./Max. Stuffing Box Dia.	M – Holder ID from Box
D – Gland Length	N – Installation Dimension
E – Min. Stuffing Box Depth	O – Shaft O-ring Number
F – Outboard Length Required	P – NPT Size
G – Min. Bolt Circle by Bolt Size	

DIMENSIONAL DATA (METRIC)

A	B MAX	C		D	E MIN	F	G MIN								H MIN	L MAX	O O-RING
		MIN	MAX				8 mm	10 mm	12 mm	14 mm	16 mm	18 mm	20 mm	22 mm			
32	125,5	47,2	53,3	37,6	4,3	45,2	79,8	81,8	83,8	85,8	87,8	-	-	-	59,9	70,9	-219
33	125,5	47,2	53,3	37,6	4,3	45,2	79,8	81,8	83,8	85,8	87,8	-	-	-	59,9	70,9	-220
35	127,4	49,3	60,5	37,6	4,3	45,2	81,8	83,8	85,8	87,8	89,8	-	-	-	66,8	72,8	-221
38	130,5	52,3	63,5	37,6	4,3	45,2	85,0	87,0	89,0	91,0	93,0	-	-	-	69,9	76,0	-223
40	133,6	55,6	66,8	37,6	4,3	45,2	87,4	89,4	91,4	93,4	95,4	-	-	-	73,2	79,0	-223
43	136,8	58,7	70,0	37,6	4,3	45,2	90,5	92,5	94,5	96,5	98,5	-	-	-	76,2	82,0	-224
45	136,8	58,7	70,0	37,6	4,3	45,2	90,5	92,5	94,5	96,5	98,5	-	-	-	76,2	82,0	-225
48	140,0	62,0	73,2	37,6	4,3	45,2	97,7	95,7	97,7	99,7	101,7	-	-	-	79,5	85,2	-226
50	143,2	65,0	76,2	37,6	4,3	45,2	98,4	100,4	102,4	104,4	106,4	-	-	-	82,6	88,4	-226
55	146,3	68,3	79,2	37,6	4,3	45,2	101,6	103,6	105,6	107,6	109,6	-	-	-	85,9	91,5	-228
60	152,6	74,7	85,6	37,6	4,3	45,2	107,8	109,8	111,8	113,8	115,8	-	-	-	92,2	97,9	-230
65	197,5	85,1	108,0	46,7	6,6	56,9	-	-	140,6	142,6	144,6	-	-	-	120,7	126,9	-231
70	197,5	85,1	108,0	46,7	6,6	56,9	-	-	140,6	142,6	144,6	-	-	-	120,7	126,9	-233
75	203,8	91,4	114,3	46,7	6,6	56,9	-	-	146,2	148,2	150,2	-	-	-	127,0	133,2	-234
80	210,2	97,8	120,7	46,7	6,6	56,9	-	-	154,8	156,8	158,8	160,8	-	-	133,4	139,5	-236
85	216,5	104,1	127,0	46,7	6,6	56,9	-	-	158,9	160,9	162,9	164,9	166,9	-	139,7	145,9	-237
90	216,5	104,1	127,0	46,7	6,6	56,9	-	-	158,9	160,9	162,9	164,9	166,9	-	139,7	145,9	-239
95	222,9	110,5	133,4	46,7	6,6	56,9	-	-	165,3	167,3	169,3	171,3	173,3	-	146,1	152,3	-241
100	229,2	116,8	139,7	46,7	6,6	56,9	-	-	171,6	173,6	175,6	177,6	179,6	-	152,4	158,6	-242
110	241,9	129,5	152,4	46,7	6,6	56,9	-	-	184,3	186,3	188,3	190,3	192,3	-	165,1	171,3	-245
115	241,9	129,5	152,4	46,7	6,6	56,9	-	-	184,3	186,3	188,3	190,3	192,3	-	165,1	171,3	-247
120	248,3	135,9	158,8	46,7	6,6	56,9	-	-	190,6	192,6	194,6	196,6	198,6	-	171,5	177,7	-248
125	286,4	150,1	177,8	73,9	7,4	87,6	-	-	-	-	-	214,5	216,5	218,5	190,5	196,5	-354
130	292,8	155,1	184,2	73,9	7,4	87,6	-	-	-	-	-	220,9	222,9	224,9	196,9	202,9	-355
135	299,1	160,1	190,5	73,9	7,4	87,6	-	-	-	-	-	227,3	229,3	231,3	203,2	209,3	-356
140	299,1	165,2	190,5	73,9	7,4	87,6	-	-	-	-	-	227,3	229,3	231,3	203,2	209,3	-358
145	305,5	170,2	196,9	73,9	7,4	87,6	-	-	-	-	-	233,7	235,7	237,7	209,6	215,7	-360
150	311,8	175,2	203,2	73,9	7,4	87,6	-	-	-	-	-	240,1	242,1	244,1	215,9	222,1	-361
155	318,2	180,1	209,6	73,9	7,4	87,6	-	-	-	-	-	246,4	248,4	250,4	222,3	228,4	-362
160	324,5	185,1	215,9	73,9	7,4	87,6	-	-	-	-	-	252,8	254,8	256,8	228,6	234,8	-363
165	324,5	190,1	215,9	73,9	7,4	87,6	-	-	-	-	-	259,2	261,2	263,2	228,6	234,8	-364
170	330,9	195,1	222,3	73,9	7,4	87,6	-	-	-	-	-	259,2	261,2	263,2	235,0	241,2	-364
175	337,2	200,2	228,6	73,9	7,4	87,6	-	-	-	-	-	265,6	267,6	269,6	241,3	247,6	-365
180	337,2	205,2	228,6	73,9	7,4	87,6	-	-	-	-	-	272,0	274,0	276,0	247,7	254,0	-366
185	343,6	210,2	235,0	73,9	7,4	87,6	-	-	-	-	-	272,0	274,0	276,0	247,7	254,0	-367
190	349,9	215,1	241,3	73,9	7,4	87,6	-	-	-	-	-	278,4	280,4	282,4	254,0	260,4	-368
195	356,3	220,1	247,7	73,9	7,4	87,6	-	-	-	-	-	284,8	286,8	288,8	260,4	266,8	-368

OPERATING LIMITS

Speed Limits:

To 4000 fpm (20 mps)

Temperature Limits:

To 250 °F (120 °C)

Pressure Limits:

All 442 seals can withstand operating pressures from full vacuum (28"/710 mm Hg) to the maximum pressures at the conditions listed below.

Small Sizes:

1.250" through 2.500" (32 mm through 60 mm)

Carbon/Ceramic -

(1750 RPM) 350 Psig/24 bar g

Carbon/Reaction Bonded Silicon Carbide -

(3600 RPM) 450 Psig/30 bar g

* Use HP holder above 300 Psig (20 bar g)

Large Sizes:

2.625" through 4.750" (65 mm through 120 mm)

Carbon/Ceramic -

(1750 RPM) 200 Psig/14 bar g

Carbon/Reaction Bonded Silicon Carbide -

(1750 RPM) 250 Psig/18 bar g

* Use HP holder above 200 Psig (14 bar g)

Extra Large Sizes:

4.875" through 7.750" (125 mm through 195 mm)

Carbon/Ceramic -

(875 RPM) 200 Psig/14 bar g

Carbon/Reaction Bonded Silicon Carbide -

(875 RPM) 200 Psig/14 bar g

* Use HP holder above 150 Psig (10 bar g)

Consult Application Engineering for higher operating conditions.

OPTIONAL 442 HP HOLDER



442 is a trademark of the A.W. Chesterton Company. Technical data reflects results of laboratory tests and is intended to indicate general characteristics only. A.W. Chesterton Company disclaims all warranties expressed, or implied, including warranties of merchantability and fitness for a particular purpose or use. Liability, if any is limited to product replacement only.



DISTRIBUTED BY:

ISO Certifications available at www.chesterton.com/corporate/iso

860 Salem Street
Groveland, Massachusetts 01834 USA
Telephone: (781) 438-7000 • Fax: (978) 469-6528
www.chesterton.com

© A.W. Chesterton Company, 2009. All rights reserved.
® Registered trademark owned and licensed by
A.W. Chesterton Company in USA and other countries.

FORM NO. 072878 REV. 4

REV. 12/09